

2012-2013

# Fossil Fuels to Products

Students learn about exploration, production, refining, chemical manufacturing, transportation, marketing, and uses of petroleum, natural gas, and their products in the industrial sector, with background information and hands-on activities.

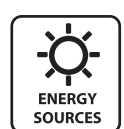
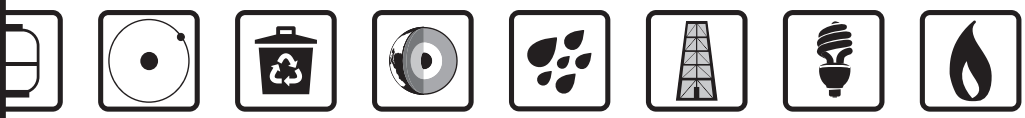
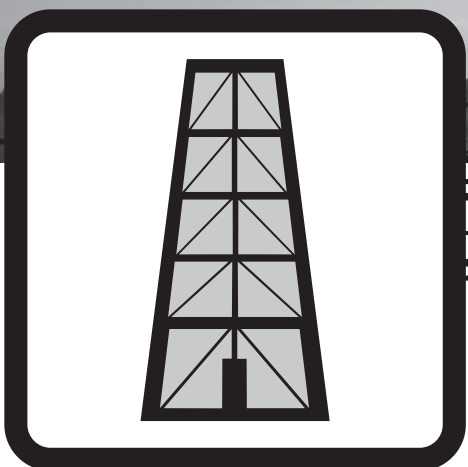

**Grade Level:**  
■ Intermediate  
■ Secondary

**Subject Areas:**  
■ Science  
■ Social Studies  
■ Language Arts  
■ Technology



## Teacher Advisory Board

**Shelly Baumann**  
Rockford, MI

**Constance Beatty**  
Kankakee, IL

**Sara Brownell**  
Canyon Country, CA

**Loree Burroughs**  
Merced, CA

**Amy Constant**  
Raleigh, NC

**Joanne Coons**  
Clifton Park, NY

**Nina Corley**  
Galveston, TX

**Regina Donour**  
Whitesburg, KY

**Linda Fonner**  
New Martinsville, WV

**Samantha Forbes**  
Vienna, VA

**Viola Henry**  
Thaxton, VA

**Robert Hodash**  
Bakersfield, CA

**DaNel Hogan**  
Kuna, ID

**Greg Holman**  
Paradise, CA

**Linda Hutton**  
Kitty Hawk, NC

**Michelle Lamb**  
Buffalo Grove, IL

**Barbara Lazar**  
Albuquerque, NM

**Robert Lazar**  
Albuquerque, NM

**Leslie Lively**  
Reader, WV

**Mollie Mukhamedov**  
Port St. Lucie, FL

**Don Pruett**  
Sumner, WA

**Josh Rubin**  
Palo Alto, CA

**Joanne Spaziano**  
Cranston, RI

**Gina Spencer**  
Virginia Beach, VA

**Tom Spencer**  
Chesapeake, VA

**Joanne Trombley**  
West Chester, PA

**Jim Wilkie**  
Long Beach, CA

**Carolyn Wuest**  
Pensacola, FL

**Wayne Yonkelowitz**  
Fayetteville, WV

## NEED Mission Statement

The mission of The NEED Project is to promote an energy conscious and educated society by creating effective networks of students, educators, business, government and community leaders to design and deliver objective, multi-sided energy education programs.

## Teacher Advisory Board Statement

In support of NEED, the national Teacher Advisory Board (TAB) is dedicated to developing and promoting standards-based energy curriculum and training.

## Permission to Copy

NEED materials may be reproduced for non-commercial educational purposes.

## Energy Data Used in NEED Materials

NEED believes in providing the most recently reported energy data available to our teachers and students. Most statistics and data are derived from the U.S. Energy Information Administration's Annual Energy Review that is published in June of each year. Working in partnership with EIA, NEED includes easy to understand data in our curriculum materials. To do further research, visit the EIA web site at [www.eia.gov](http://www.eia.gov). EIA's Energy Kids site has great lessons and activities for students at [www.eia.gov/kids](http://www.eia.gov/kids).



1.800.875.5029

[www.NEED.org](http://www.NEED.org)

© 2012



Printed on Recycled Paper



*Fossil Fuels to Products* was developed by The NEED Project and the Center for the Advancement of Process Technology (CAPT) with funding from Shell Oil Company.

Special thanks to the Society of Petroleum Engineers for their assistance with teacher lessons for this guide. For more resources, visit [www.energy4me.org](http://www.energy4me.org).

# Fossil Fuels to Products

## Table of Contents

|  |    |
|--|----|
| ▪ National Science Education Standards             | 4  |
| ▪ Teacher Guide                                    | 7  |
| ▪ Introduction to Oil and Gas                      | 10 |
| ▪ Petroleum Based Transportation Fuels             | 19 |
| ▪ Careers in the Oil and Gas Industry              | 23 |
| ▪ Oil and Gas Career Game                          | 24 |
| ▪ NEED Industry Professional Q&A's                 | 25 |
| ▪ Graphic Organizers                               | 31 |
| ▪ Jigsaw Role Questions and Presentation Questions | 35 |
| ▪ Formation of Oil and Natural Gas                 | 36 |
| ▪ Exploring Sound Waves                            | 38 |
| ▪ Exploring Core Sampling                          | 39 |
| ▪ Exploring Density                                | 40 |
| ▪ Exploring Porosity                               | 41 |
| ▪ Getting the Oil Out                              | 42 |
| ▪ Distillation Products                            | 43 |
| ▪ Fractional Distillation Master                   | 44 |
| ▪ Refinery Product Cards                           | 45 |
| ▪ The Refining Process                             | 46 |
| ▪ Polymers   | 47 |
| ▪ Slush Powder                                     | 49 |
| ▪ Chemical Hazard Placards                         | 50 |
| ▪ Pretzel Power                                    | 53 |
| ▪ Oil Industry in the Round                        | 54 |
| ▪ Synthesis Activity                               | 55 |
| ▪ Fossil Fuels to Products Pre/Post Survey         | 56 |
| ▪ Glossary   | 57 |
| ▪ Evaluation Form                                  | 59 |

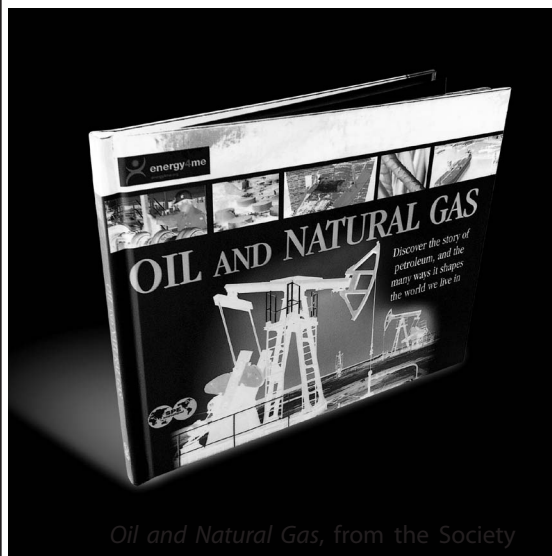

*Oil and Natural Gas*, from the Society of Petroleum Engineers, is a great classroom resource that supplements the information and activities in *Fossil Fuels to Products*. To order, visit <http://www.energy4me.org/order/oil-and-natural-gas/>.

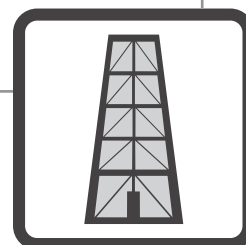



# Correlations to National Science Education Standards: Grades 5-8

This book has been correlated to National Science Education Content Standards.

For correlations to individual state standards, visit [www.NEED.org](http://www.NEED.org).

## Content Standard B | *PHYSICAL SCIENCE*

---

### ▪ **Properties and Changes of Properties in Matter**

- A substance has characteristic properties, such as density, a boiling point, and solubility, all of which are independent of the amount of the sample. A mixture of substances often can be separated into the original substances using one or more of the characteristic properties.

### ▪ **Transfer of Energy**

- Energy is a property of many substances and is associated with heat, light, electricity, mechanical motion, sound, nuclei, and the nature of a chemical. Energy is transferred in many ways.
- In most chemical and nuclear reactions, energy is transferred into or out of a system. Heat, light mechanical motion, or electricity might all be involved in such transfers.
- The sun is a major source of energy for changes on the earth's surface. The sun loses energy by emitting light. A tiny fraction of that light reaches the earth, transferring energy from the sun to the earth. The sun's energy arrives as light with a range of wavelengths, consisting of visible light, infrared, and ultraviolet radiation.

## Content Standard C | *LIFE SCIENCE*

---

### ▪ **Populations and Ecosystems**

- For ecosystems, the major source of energy is sunlight. Energy entering ecosystems as sunlight is transferred by producers into chemical energy through photosynthesis. That energy then passes from organism to organism in food webs.

## Content Standard D | *EARTH AND SPACE SCIENCE*

---

### ▪ **Structure of the Earth System**

- Some changes in the solid earth can be described as the "rock cycle." Old rocks at the earth's surface weather, forming sediments that are buried, then compacted, heated, and often recrystallized into new rock. Eventually, those new rocks may be brought to the surface by the forces that drive plate motions, and the rock cycle continues.
- Living organisms have played many roles in the earth system, including affecting the composition of the atmosphere, producing some types of rocks, and contributing to the weathering of rocks.

## Content Standard E | *SCIENCE AND TECHNOLOGY*

---

### ▪ **Understandings about Science and Technology**

- Perfectly designed solutions do not exist. All technological solutions have trade-offs, such as safety, cost, efficiency, and appearance. Engineers often build in back-up systems to provide safety. Risk is part of living in a highly technological world. Reducing risk often results in new technology.

## Content Standard F | *SCIENCE IN PERSONAL AND SOCIAL PERSPECTIVES*

---

### ▪ **Risks and Benefits**

- Students should understand the risks associated with natural hazards (fires, floods, tornadoes, hurricanes, earthquakes, and volcanic eruptions), with chemical hazards (pollutants in air, water, soil, and food), with biological hazards (pollen, viruses, bacterial, and parasites), social hazards (occupational safety and transportation), and with personal hazards (smoking, dieting, and drinking).

### ▪ **Science and Technology in Society**

- Technology influences society through its products and processes. Technology influences the quality of life and the ways people act and interact. Technological changes are often accompanied by social, political, and economic changes that can be beneficial or detrimental to individuals and to society. Social needs, attitudes, and values influence the direction of technological development.





# Correlations to National Science Education Standards: Grades 9-12

This book has been correlated to National Science Education Content Standards.

For correlations to individual state standards, visit [www.NEED.org](http://www.NEED.org).

## Content Standard B | *PHYSICAL SCIENCE*

---

### ▪ **Structure and Properties of Matter**

- Carbon atoms can bond to one another in chains, rings, and branching networks to form a variety of structures, including synthetic polymers, oils, and the large molecules essential to life.

### ▪ **Chemical Reactions**

- Chemical reactions occur all around us, for example in health care, cooking, cosmetics, and automobiles. Complex chemical reactions involving carbon-based molecules take place constantly in every cell in our bodies.
- Chemical reactions may release or consume energy. Some reactions such as the burning of fossil fuels release large amounts of energy by losing heat and by emitting light. Light can initiate many chemical reactions such as photosynthesis and the evolution of urban smog.

## Content Standard E | *SCIENCE AND TECHNOLOGY*

---

### ▪ **Understandings about Science and Technology**

- Scientists in different disciplines ask different questions, use different methods of investigation, and accept different types of evidence to support their explanations. Many scientific investigations require the contributions of individuals from different disciplines, including engineering. New disciplines of science, such as geophysics and biochemistry often emerge at the interface of two older disciplines.
- Science often advances with the introduction of new technologies. Solving technological problems often results in new scientific knowledge. New technologies often extend the current levels of scientific understanding and introduce new areas of research.
- Creativity, imagination, and a good knowledge base are all required in the work of science and engineering.

## Content Standard F | *SCIENCE IN PERSONAL AND SOCIAL PERSPECTIVES*

---

### ▪ **Natural Resources**

- Human populations use resources in the environment in order to maintain and improve their existence. Natural resources have been and will continue to be used to maintain human populations.
- The earth does not have infinite resources; increasing human consumption places severe stress on the natural processes that renew some resources, and it depletes those resources that cannot be renewed.
- Humans use natural systems as resources. Natural systems have the capacity to reuse waste, but that capacity is limited. Natural systems can change to an extent that exceeds the limits of organisms to adapt naturally or humans to adapt technologically.

### ▪ **Environmental Quality**

- Natural ecosystems provide an array of basic processes that affect humans. Those processes include maintenance of the quality of the atmosphere, generation of soils, control of the hydrologic cycle, disposal of wastes, and recycling of nutrients. Humans are changing many of these basic processes, and the changes may be detrimental to humans.
- Materials from human societies affect both physical and chemical cycles of the earth.
- Many factors influence environmental quality. Factors that students might investigate include population growth, resource use, population distribution, overconsumption, the capacity of technology to solve problems, poverty, the role of economic, political, and religious views, and different ways humans view the earth.

### ▪ **Natural and Human-Induced Hazards**

- Human activities can enhance potential for hazards. Acquisition of resources, urban growth, and waste disposal can accelerate rates of natural change.
- Natural and human-induced hazards present the need for humans to assess potential danger and risk. Many changes in the environment designed by humans bring benefits to society, as well as cause risks. Students should understand the costs and trade-offs of various hazards—ranging from those with minor risk to a few people to major catastrophes with major risk to many people. The scale of events and the accuracy with which scientists and engineers can (and cannot) predict events are important considerations.

### ▪ **Science and Technology in Local, National, and Global Challenges**

- Science and technology are essential social enterprises, but alone they can only indicate what can happen, not what should happen. The latter involves human decisions about the use of knowledge.
- Understanding basic concepts and principles of science and technology should precede active debate about the economics, policies, politics, and ethics of various science- and technology-related challenges. However, understanding science alone will not resolve local, national, or global challenges.

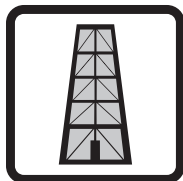

# Materials Needed for Fossil Fuels to Products Activities

| ACTIVITY                | MATERIALS  |
|-------------------------|--|
| Exploring Sound Waves   | <ul style="list-style-type: none"> <li>▪ 1 Metal slinky spring</li> <li>▪ 1 Large foam cup</li> <li>▪ 1 Small foam cup</li> </ul>  |
| Exploring Core Sampling | <ul style="list-style-type: none"> <li>▪ 1 Bag of dark sand</li> <li>▪ 1 Bag of light sand</li> <li>▪ 1 Bag of soil</li> <li>▪ 1 Bag of small gravel (aquarium size)</li> <li>▪ 1 Clear plastic straw per student</li> <li>▪ 1 Opaque plastic cup per student (8 ounce)</li> <li>▪ Water in a spray bottle</li> <li>▪ Plastic spoons</li> <li>▪ Ruler</li> </ul> |
| Exploring Density       | <ul style="list-style-type: none"> <li>▪ 100 mL Graduated cylinder</li> <li>▪ 600 mL Beaker</li> <li>▪ Corn syrup</li> <li>▪ Water, dyed with food coloring</li> <li>▪ Vegetable oil</li> <li>▪ Plastic button</li> <li>▪ Grape</li> <li>▪ Small cork</li> <li>▪ Penny</li> <li>▪ Glass marble</li> <li>▪ Wooden bead</li> <li>▪ Ice cube</li> </ul>             |
| Exploring Porosity      | <ul style="list-style-type: none"> <li>▪ 1 Bag large gravel (coarse gravel)</li> <li>▪ 1 Bag small gravel (aquarium type)</li> <li>▪ 1 Bag medium gravel (pea gravel)</li> <li>▪ Water (can be dyed with food coloring)</li> <li>▪ 3 600 mL Beakers or tall clear cups or jars</li> <li>▪ 1 100 mL Graduated cylinder</li> </ul>                                 |
| Getting the Oil Out     | <ul style="list-style-type: none"> <li>▪ 8-10 Drinking straws</li> <li>▪ Masking tape</li> <li>▪ Scissors</li> <li>▪ Carton of chocolate milk or other beverage (preferably a dark color so it can be seen through the straw)</li> </ul>   |
| Distillation Products   | <ul style="list-style-type: none"> <li>▪ Master of <i>Fractional Distillation</i> graphic, page 44</li> <li>▪ <i>Refinery Product Cards</i>, page 45</li> <li>▪ Projector</li> <li>▪ White board</li> </ul>  |

| ACTIVITY                 | MATERIALS  |
|--------------------------|--|
| The Refining Process     | <ul style="list-style-type: none"> <li>▪ 400 mL 2% Milk</li> <li>▪ 100 mL Vinegar</li> <li>▪ Saucepan</li> <li>▪ Wooden spoon</li> <li>▪ Hot plate</li> <li>▪ Pot holder</li> <li>▪ Safety glasses</li> </ul>  |
| Polymers                 | <ul style="list-style-type: none"> <li>▪ Cornstarch</li> <li>▪ Water</li> <li>▪ Sealable plastic sandwich bags</li> <li>▪ Measuring spoons</li> <li>▪ Food coloring</li> <li>▪ Paper plates</li> <li>▪ White glue</li> <li>▪ Borax</li> <li>▪ Spoon or popsicle stick to stir</li> <li>▪ Small plastic cups</li> <li>▪ Food coloring</li> <li>▪ Graduated cylinder</li> <li>▪ Ruler</li> </ul> |
| Slush Powder             | <ul style="list-style-type: none"> <li>▪ Sodium polyacrylate</li> <li>▪ 400 mL Beaker</li> <li>▪ 25 mL Graduated cylinder</li> <li>▪ Water</li> <li>▪ Salt (optional)</li> </ul>   |
| Chemical Hazard Placards | <ul style="list-style-type: none"> <li>▪ Copies of pages 50-52 for each student</li> </ul>   |
| Pretzel Power            | <ul style="list-style-type: none"> <li>▪ 3" x 5" Cards</li> <li>▪ Internet access for students</li> <li>▪ Bag of pretzels</li> <li>▪ Plastic sandwich bags</li> <li>▪ Three signs (Home, Near Town, Far Town)</li> </ul>   |
| Synthesis Activity       | <ul style="list-style-type: none"> <li>▪ Large piece of mural paper</li> <li>▪ Colored markers</li> </ul>  |

**Science Notebooks:** It is recommended that students record their data, observations, and conclusions in science notebooks during the *Fossil Fuels to Products* activities. If your students do not already use science notebooks, they can be easily made by stapling sheets of line, graph, or blank paper inside of a construction paper cover.



# Teacher Guide

To teach students about the exploration, production, refining, and chemical manufacturing of oil and gas using background information, graphic organizers, cooperative learning, and hands-on activities.

## Background

---

The United States uses more petroleum than any other energy resource. Petroleum products are used to manufacture many of the plastics and other vital products we use every day to maintain our lifestyle and economy.

## Time

---

Three to ten 45-minute class periods, depending on the number of activities you choose to conduct

## Preparation

---

- Familiarize yourself with the information and activities in the booklet.
- Make copies of the pages you are going to use for each student (two copies of the survey for pre and post activity).
- Make a master of page 44 if you are conducting the *Distillation Products* activity.
- Make a copy of page 54 on cardstock and cut out the cards if you are conducting the *Oil Industry in the Round* activity.
- Gather the materials you need to conduct the hands-on activities, as listed in each activity. The activities are designed so that the materials are inexpensive; most materials are available in the school science lab, or can be obtained at hardware, pet, and craft stores. If you have difficulty locating any of the materials you need, please email NEED at [info@need.org](mailto:info@need.org) for information on where you can purchase the materials.

## Procedure

---

### Activity One: Introducing the Unit

1. Introduce the activity by asking the students the following questions:
  - What are petroleum and natural gas?
  - Where do they come from?
  - How are they retrieved?
  - How are they turned into useful products?
  - What petroleum products do we use every day?
  - What is their impact on society in the U.S.?
2. Explain to the students that they will learn about all of these things by taking on the roles of experts in the industry and consumers in the jigsaw activity described below, as well as by participating in hands-on activities.
3. Have the students take the survey on page 56 to establish baseline knowledge. Have the students self-grade the surveys, determine the average number of correct answers as a benchmark, mark the surveys as PRE, and save them.

### Activity Two: Jigsaw

1. Divide the students into six groups. Assign each group one of six specific roles, as listed below. These groups are the role groups. Also assign the students to presentation groups, in which they will share their role expertise. Each presentation group should include at least one member from each role group.
  - Geologist
  - ROVER Operator
  - Lab Technician
  - Process Technician
  - Pipeline Inspector
  - Consumer
2. Explain the jigsaw assignment to the students. Give each student the list of questions for his/her role group (page 35). Explain that the questions will guide their reading and research. Explain that they will be involved in answering the questions over several days as they participate in the readings and other activities. They will use the information they have gathered to design and present projects at the end of the unit in their presentation groups.

**CONTINUED ON PAGE 8**

### **CONTINUED FROM PAGE 7**

3. Instruct the students to use the background material, as well as outside research, to answer their questions as completely as possible.
4. When the students have read all of the background sections and completed their research, have the role groups meet to discuss their findings. Instruct the students to add to their notes any additional information provided by group members.
5. After the students have met in the role groups and completed their discussions, assign them to their presentation groups. Explain that these groups will synthesize the information collected by the different role groups.
6. Distribute copies of the presentation questions to each student (page 35). Instruct the presentation groups to work together to answer the presentation questions, collecting members' ideas from each of the role areas.
7. After the groups have answered all of the presentation questions, instruct each presentation group to choose a product with which to present their findings. Suggested products include a PowerPoint presentation, a brochure, an expo display board, a song or rap, a school newspaper article, an advertisement, a video, or any other format acceptable to the teacher.
8. Give the groups a timeframe in which to complete and present their projects.
9. Use the *Presentation Rubric* on the following page to evaluate the projects.

### **Careers**

1. An oil and gas industry career glossary, game, and questions and answers with industry professionals can be found on pages 23-30.

### **Organizers and Hands-on Activities**

1. Divide the lessons into the four sections listed below. For each section, have the students read the background section listed and complete the graphic organizer for that section (pages 31-34).
2. Complete the hands-on activities for each section and discuss the background information and activities before proceeding to the next section. Instructions for the hands-on activities and the materials needed are included with the activities. It is suggested that students record what they learn from the hands-on activities in science notebooks.

**Section 1:** What is Petroleum? through Exploration

**Section 2:** Retrieving the Oil, Production, and Shipping Crude Oil

**Section 3:** Refining and Shipping Petroleum Products

**Section 4:** Chemical Manufacturing, Plant Equipment and Processes, Transportation, Products, Health and Safety, and Into the Future

3. After the students have completed these activities, conduct the *Oil Industry in the Round* activity to reinforce new vocabulary.
4. Return to Step 4 of the Jigsaw activity above and complete the activity.

### **Transportation Fuels Activity: Pretzel Power**

1. Students explore the energy efficiency of automobiles.
2. Follow the instructions on page 53.

### **Vocabulary Reinforcement Activity: Oil Industry in the Round**

1. Make a copy of page 54 on cardstock and cut out the cards.
2. Distribute the cards randomly to the students. If you have fewer than 30 students in the class, give some students two cards. All of the cards must be distributed for the activity to succeed.
3. If you have more than 30 students, have the remaining students serve as arbiters of disputes and allow them to participate in a second round.
4. Explain the instructions for the game, as follows:
  - The student with the card labeled START reads the question that follows the word START, "Who has...."
  - The student who has the answer stands up and responds by reading his/her card, "I have \_\_\_\_\_. Who has \_\_\_\_\_?"
  - This procedure continues until every person has read his/her card and the question has returned to the starter, who answers the last question, and says, "The End."
5. Collect the cards and redistribute randomly to play another round.

## Synthesis Activity: Fossil Fuels to Products

1. Follow the instructions on page 55 for the *Synthesis Activity*.

## Evaluation

- Evaluate individual student performance using the graphic organizers and science notebooks.
- Evaluate presentations for the Jigsaw activity using the rubric below.
- Have the students take the survey on page 56 again, self-grade, and determine the average number of correct answers to determine knowledge gain. Mark the surveys as POST and send to NEED.
- Evaluate the entire unit with your students using the *Evaluation Form* on page 59 and fax to The NEED Project at 1-800-847-1820 or mail to:  
The NEED Project  
P.O. Box 10101  
Manassas, VA 20108

## Answer Keys

**Survey Answer Key** (the survey is on page 56)

1. d 2. b 3. a 4. d 5. b 6. b 7. c 8. b 9. a 10. b 11. a 12. a 13. b 14. b 15. a 16. a

**Production Activity—Exploring Density Answer Key**

Densities: Oil:  $0.881 \text{ g/cm}^3$  Aluminum:  $2.70 \text{ g/cm}^3$  Copper:  $8.93 \text{ g/cm}^3$  Nickel:  $8.90 \text{ g/cm}^3$

**Chemical Manufacturing Activity—Identifying Chemical Hazard Placards Answer Key**

A: butane B: calcium C: benzene D: sulfuric acid E: phosphorus F: methane

## Presentation Rubric

|   | CONTENT   | ORGANIZATION   | ORIGINALITY  | WORKLOAD   |
|---|---|--|--|--|
| 4 | Project covers the topic in-depth with many details and examples. Subject knowledge is excellent. | Content is very well organized and presented in a logical sequence.      | Project shows much original thought. Ideas are creative and inventive.                     | The workload is divided and shared equally by all members of the group.                                  |
| 3 | Project includes essential information about the topic. Subject knowledge is accurate.            | Content is organized in a logical sequence.                              | Project shows some original work. Work shows new ideas and insights.                       | The workload is divided and shared fairly equally by all group members, but workloads may vary.          |
| 2 | Project includes essential information about the topic, but there are 1-2 factual errors.         | Content is logically organized but may have a few confusing sections.    | Project provides essential information, but there is little evidence of original thinking. | The workload is divided, but one person in the group is viewed as not doing a fair share of the work.    |
| 1 | Project includes minimal information or there are several factual errors.                         | There is no clear organizational structure, just a compilation of facts. | Project provides some essential information, but no original thought.                      | The workload is not divided, or it is evident that one person is doing a significant amount of the work. |

## Web Resources

**Career Currents, February/March 2011**

<http://need.org/needpdf/careerCurrents1102.pdf>

**Career Currents, October 2005**

[www.need.org/needpdf/OCT2005NewsletterWEB-1.pdf](http://www.need.org/needpdf/OCT2005NewsletterWEB-1.pdf)

**The Virtual Chemical Plant**

<http://capt.com.edu/virtualchemplant/>

**Energize Your Future With Shell**

[www.shell.com/us/energizeyourfuture/](http://www.shell.com/us/energizeyourfuture/)

**Energy4Me**

[www.energy4me.org](http://www.energy4me.org)

**EIA Kids Page**

<http://www.eia.gov/kids/>

**Energy Explained from the Energy Information Administration**

[http://www.eia.gov/energyexplained/index.cfm?page=oil\\_home](http://www.eia.gov/energyexplained/index.cfm?page=oil_home)



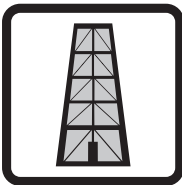

# Introduction to Oil and Gas

## What is Petroleum?

Petroleum is a fossil fuel. Petroleum is often called crude oil, or just oil. It is considered a fossil fuel because it was formed from the remains of tiny sea plants and animals that died millions of years ago. When the plants and animals died, they sank to the bottom of the oceans. Over time, they were buried by thousands of feet of sand and sediment, which turned into sedimentary rock. As the layers increased, they pressed harder and harder on the decayed remains at the bottom. The heat and pressure eventually changed the remains into petroleum. Petroleum is classified as a nonrenewable energy source because it takes millions of years to form. We cannot make new petroleum reserves in a short period of time.

Even though oil and natural gas come from ancient plant and animal matter, in geologic time, they are young. Most oil comes from rocks that are about 400 million years old or younger. Scientists believe the Earth is over four billion years old, with life existing on Earth for

about 3.7 billion years. Dinosaurs first roamed the Earth about 248 million years ago.

Like all once-living things, petroleum is a mixture made of several carbon compounds such as hydrogen butanes and olefins, and is an excellent source of energy. Because the living things that turned into petroleum did not have the opportunity to complete the decay process, there is a great deal of chemical energy in their molecular bonds.

Petroleum deposits are locked in porous rocks like water is trapped in a wet sponge. Petroleum, just out of the ground, is called crude oil. When crude oil comes out of the ground, it can be as thin as water or as thick as tar. The characteristics of crude oil vary in different locations. Some crude is very clear and moves like water. This is usually called light crude. Other crude is very dark and almost a solid at normal temperatures.

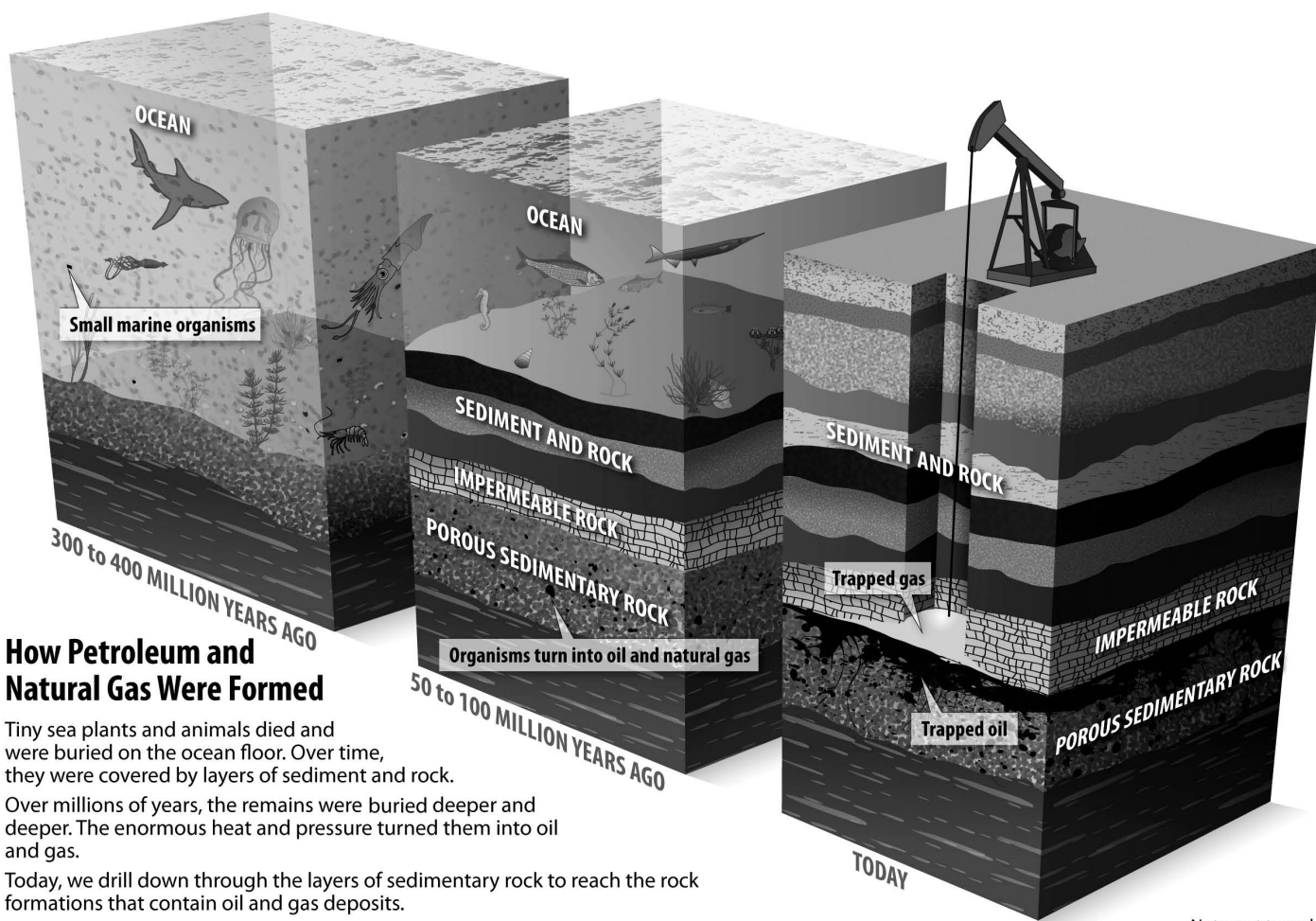

### How Petroleum and Natural Gas Were Formed

Tiny sea plants and animals died and were buried on the ocean floor. Over time, they were covered by layers of sediment and rock.

Over millions of years, the remains were buried deeper and deeper. The enormous heat and pressure turned them into oil and gas.

Today, we drill down through the layers of sedimentary rock to reach the rock formations that contain oil and gas deposits.

Note: not to scale



## History of Oil

People have used petroleum since ancient times. The early Chinese and Egyptians burned oil to light their homes. Before the 1850s, Americans used whale oil to light their homes. When whales became scarce, people skimmed the crude oil that seeped to the surface of ponds and streams. Did you know that oil floats on water? The density of oil is less than the density of water, allowing it to float to the top.

The demand for oil grew and in 1859, Edwin Drake drilled the first oil well near Titusville, PA. At first, the crude oil was refined into kerosene for lighting. Gasoline and other products produced during refining were thrown away because people had no use for them.

This all changed when Henry Ford began mass producing automobiles in 1913. Everyone wanted automobiles, and they all ran on gasoline. Gasoline was the fuel of choice because it provided the greatest amount of energy relative to cost and ease of use.

Today, Americans use more petroleum than any other energy source, mainly for transportation. Petroleum provides 35 percent of the total energy we use. One-third of the oil the U.S. produces comes from offshore wells. Some of these wells are a mile under the ocean. Some of the rigs used to drill these wells float on top of the water. It takes a lot of money and technology to find, explore, produce, and transport oil from under the ocean.

Texas produces more oil than any other state, followed by Alaska, California, North Dakota, and Oklahoma. Americans use much more oil than we produce. Today, the U.S. imports half of the oil it consumes from foreign countries.

## Oil and the Environment

Petroleum products—gasoline, medicines, fertilizers, and others—have helped people all over the world. Petroleum production and use are not without risk, however; environmental damage can result if oil and its products are not handled correctly. If drilling is not carefully regulated, it may disturb fragile land and ocean environments. Transporting oil may endanger wildlife if oil is spilled into rivers and oceans. Burning gasoline to fuel our cars pollutes the air. Even the careless disposal of motor oil drained from the family car can pollute streams and rivers.

The petroleum industry works hard to protect the environment. Gasoline and diesel fuel have been processed to burn cleaner, and oil companies do everything they can to drill, process, and transport oil and its products as safely as possible.



Image courtesy of Doug Stewart, contributor to Wikimedia Commons

A replica of the Drake Well in Titusville, PA.

### Petroleum Consumption by Sector, 2010

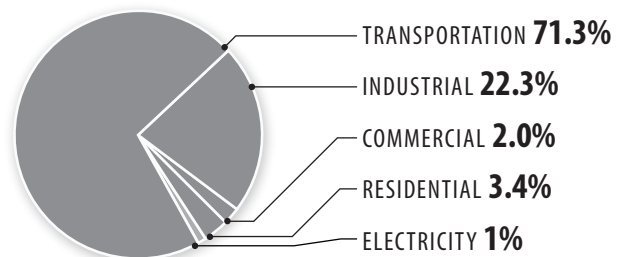

Data: Energy Information Administration

### Top Petroleum Producing States, 2010

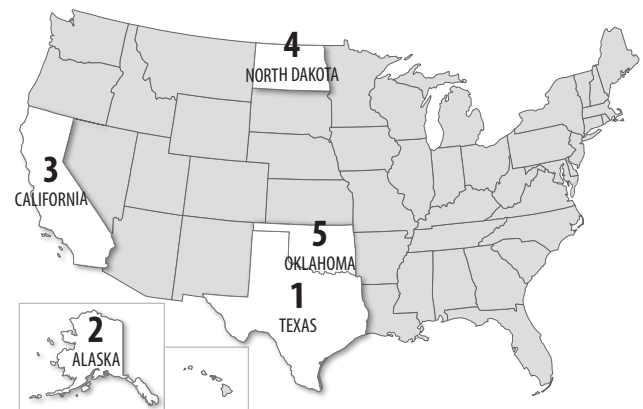

Data: Energy Information Administration

## What is Natural Gas?

Natural gas is a fossil fuel like petroleum and coal. Natural gas is considered a fossil fuel because most scientists believe that it was formed from the remains of ancient sea plants and animals. When the plants and tiny sea animals died, they sank to the bottom of the oceans where they were buried by sediment and sand, which turned into sedimentary rock. The layers of plant and animal matter and sedimentary rock continued to build until the pressure and heat from the Earth turned the remains into petroleum and natural gas.

Natural gas is trapped in underground rocks, much like water is trapped in the pockets of a sponge. Natural gas is really a mixture of gases. The main ingredient is methane. Methane has no color, odor, or taste. As a safety measure, gas companies add an odorant, mercaptan, to the natural gas that we use in our homes and buildings so that leaking gas can be detected (it smells like rotten eggs). Natural gas should not be confused with gasoline, which is a petroleum product.

Natural gas from underground reservoirs is considered a nonrenewable energy source, which means we cannot make more in a short time.

## History of Natural Gas

The ancient people of Greece, Persia, and India discovered natural gas many centuries ago. The people were mystified by the burning springs created when natural gas seeped from cracks in the ground and was ignited by lightning. They sometimes built temples around these eternal flames and worshipped the fire.

About 2,500 years ago, the Chinese recognized that natural gas could be put to work. The Chinese piped the gas from shallow wells and burned it under large pans to evaporate seawater to make salt.

In 1816, natural gas captured from a coal coking plant was first used in America to fuel street lamps in Baltimore, MD. Soon after, in 1821, William Hart dug the United States' first successful natural gas well in Fredonia, NY. It was just 27 feet deep, quite shallow compared to today's wells. Today, natural gas is the country's second largest source of energy, meeting over 25 percent of our total energy demand.

## Who Uses Natural Gas?

Just about everyone in the United States uses natural gas. Industry is the biggest user. Industry burns natural gas to produce heat to manufacture many of the products we use every day. Natural gas is also used as an ingredient, or feedstock, in fertilizer, glue, paint, laundry detergent, and many other products.

Natural gas can be used to generate electricity. Many utilities are building new power plants that burn natural gas because it is clean burning and natural gas plants can produce electricity quickly when it is needed for periods of peak demand. Electricity generation is the second biggest user of natural gas today.

## Natural Gas Use by Sector, 2010

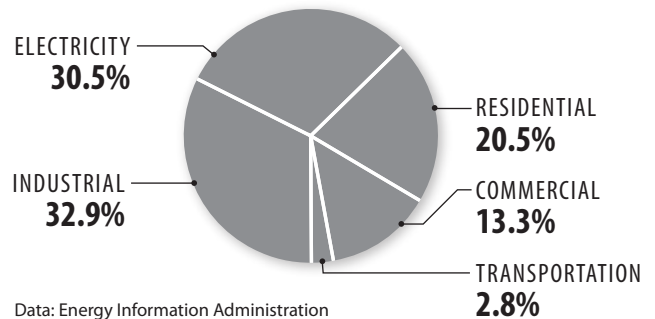

Natural gas is used to power some fork lifts.

Residences, or homes, are the third biggest users of natural gas. Five in ten homes use natural gas for heating, and many also use it for cooking and heating water. Commercial buildings use natural gas too. Commercial users include stores, offices, schools, churches, and hospitals.

A small amount of natural gas is used as fuel for automobiles. Natural gas is cleaner burning than gasoline, but vehicles must have special equipment to use it. Many of the vehicles used by the government in national parks operate on compressed natural gas.

## Natural Gas and the Environment

Burning any fossil fuel, including natural gas, releases emissions into the air, as well as carbon dioxide, a greenhouse gas. Natural gas (and propane) are the cleanest burning fossil fuels because they have fewer carbon atoms to form carbon dioxide. Compared to coal and petroleum, natural gas releases much less sulfur, carbon, and ash when it is burned. Because it is a clean source of energy, scientists are looking for new sources of natural gas and new ways to use it.

## Exploration

### Geology

Oil and natural gas are buried beneath the Earth's crust, on land and under the oceans. To find it, geologists use their knowledge of land and rock formations, the geologic history of an area, and sophisticated technology. Combining all this information, geologists are more likely to be successful when they drill. Even with all this, not all wells produce oil or natural gas. Exploratory wells are drilled if scientists think an area has oil. For every 100 exploratory wells drilled, 61 of them will find oil or natural gas.

By the time production wells are drilled, the success rate has risen to about 91 percent. To increase the success of drilling, petroleum geologists must be knowledgeable in a number of areas.

### Rock Formation

The field of stratigraphy is the study of rock layers (or strata) to determine the type of rock formation, the age of the layers, the radioactivity of the formations, and other information to determine the composition, origin, and location of rock strata.

Compiling information on rock formations is an important part of oil and gas exploration. Different types of rock have varying potential for holding oil or gas in a reservoir. There are three different types of rock: sedimentary, metamorphic, and igneous. Every rock fits into one of these three categories.

**Metamorphic rock** began as either sedimentary or igneous rock that was exposed to increased pressure and heat that eventually transformed it into metamorphic rock. Usually metamorphic rock is found near other types of rock. It is also usually denser than sedimentary rock since heat and pressure have removed many of the pores from it.

**Igneous rock** is formed from magma, or liquid rock, that exists in the Earth's core. Sometimes where cracks or faults occur in the Earth's crust, magma can seep up and cool, creating igneous rock. Igneous rock can also be created when magma makes its way to the Earth's surface in the form of lava. Igneous rock is usually the densest of the three rock types.

**Sedimentary rock** is formed by the build-up of layers of sand and sediment over time. These layers are created as materials on the Earth's surface are eroded and washed downstream. Over thousands of years, these particles are compressed to create rock. Most oil is found in sedimentary rock. Since sedimentary rock often has many pores, it is an ideal formation to contain oil and natural gas.

## Oil and Gas Basins

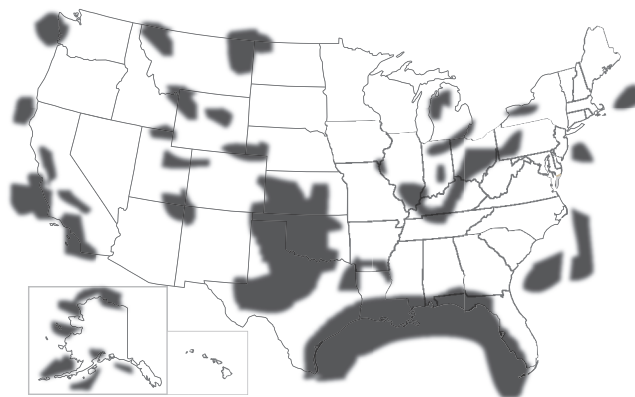

## Oil and Natural Gas Exploration

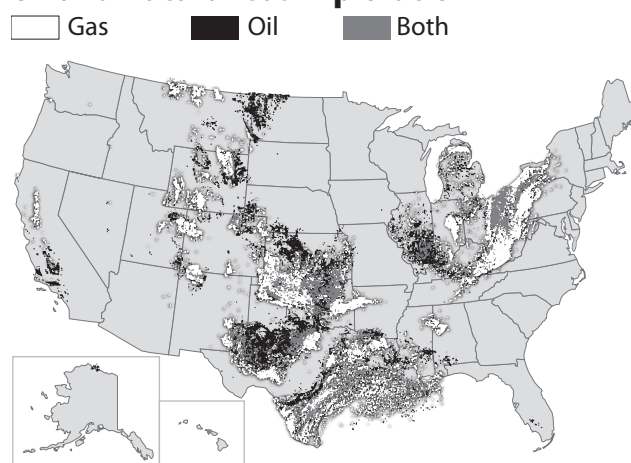

Data: Energy Information Administration

## The Rock Cycle

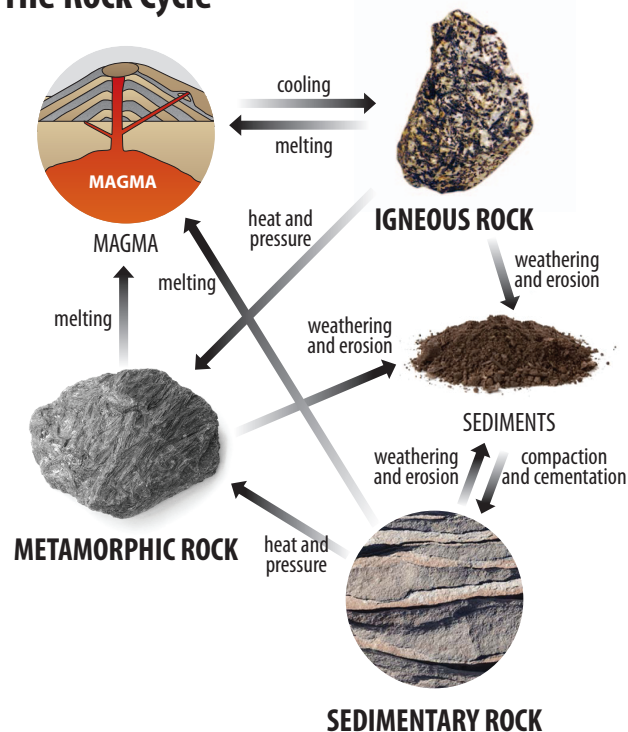



## Permeability

Oil and natural gas occur naturally in the Earth's layers, inside of rocks. Rocks are not completely solid; they have tiny holes, or pores, in which air or other fluids were trapped during formation. The porosity of a rock formation is a measure of the number and kind of pores it has.

Fluids can move between rock pores in varying degrees. Permeability is a measure of the ability of a rock to move fluids through its pores. Permeability is a very important feature for finding oil and gas. Being successful at finding oil is partially determined by locating porous rock, as well as locating other fluids, such as water, that are contained in rock formations.

## Geologic History

An important factor in finding oil and gas is understanding the environment that existed in an area millions of years ago. Since oil and natural gas are the remains of ancient sea life, the first step in locating oil is finding areas where ancient seas once existed.

## Seismic Technology

Seismic technology uses sound waves to reveal what lies deep in the ground. Sound waves can travel through some materials more easily than others. When sound waves are directed into the ground and they hit something they cannot penetrate, they bounce back, returning to the surface. Equipment on the surface records the returning waves. Once the waves have all been recorded for an area, the information is taken back to a lab where geoscientists read the waves. A map can then be created of the underground terrain.

The first seismic instruments were used in the mid 1800s to detect earthquakes. Seismic equipment began being used in the oil fields in the 1920s. In those days, dynamite was used to create the sound waves. The data collected had to be read by hand. In the 1960s, digital technology allowed the information to be read by machine. Three-dimensional seismic data was first used in the late 1960s and changed the way seismographs were used. Today, machines called thumpers are used to create shock waves instead of dynamite. To create a 3D image of the layer of ground, not one, but many seismic instruments are used. They are placed in holes around a site. Each of these instruments records sound waves. Then scientists can combine all of these images to get a better understanding of what lies underground.

When searching for oil under the sea floor, seismic equipment must be adapted for the marine environment. Seismic systems are placed on ships and the listening devices are attached to long streamers. Many ships have four or five streamers, but some larger ships may have up to 16 streamers.

Another way scientists analyze the ocean floor is with ocean bottom cables. These cables are sent to the ocean floor from a stationary platform. Then, a ship towing air guns passes by. The air guns, directed down, are used to create the sound waves.

## Interpreting Seismic Output

Today, seismic data is interpreted in high tech ways. 3D visualization puts seismic information into a three-dimensional format that people can more easily understand. One of the most advanced 3D visualization projects is known as the CAVE (Cave Automatic Virtual Environment). The CAVE is an entire room used for visualization. In this virtual reality environment, the walls and floor are used as projection surfaces, giving the appearance of filling the room and allowing scientists to walk into the data.

## Land-based Seismic

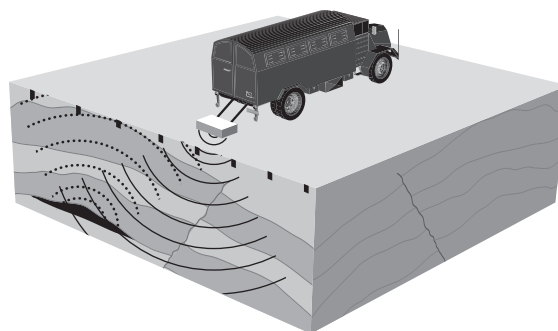

## Ocean-based Seismic

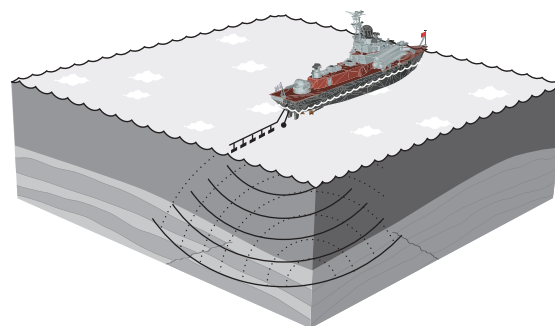

## THE CAVE 3D SEISMIC VISUALIZATION ROOM



The newest type of seismic technology is 4D seismic. The fourth dimension is time. 4D seismic uses a number of 3D images taken over time to see how they change. This technology is often used in areas that are already producing oil to see how production is affecting the reserve.

Other surveying techniques include gravitational, magnetic, and radioactive processes, all of which measure physical properties of a site and use that information to determine whether oil or gas is present.

## Retrieving the Oil

### Permitting and Leasing Land

Once a site has the potential for oil extraction, companies must get permission to drill. In some areas, this means acquiring the needed permits from state government and leases from landowners to drill on private land. In other cases, the land is federal land and require leases and permits from the U.S. Bureau of Land Management (for onshore drilling) or the Bureau of Ocean Energy Management, and the Bureau of Safety and Environmental Enforcement (for offshore drilling). There are also environmental protection measures that must be in place before drilling can begin.

### Drilling

Since the first oil well was drilled in 1859 by Edwin Drake, oil production has become an increasingly complex and precise process. The original methods of drilling for oil were based on ancient methods for finding water and salt. As wells have gotten deeper and more complex, drilling technology has also become more complex.

To drill a well, a large drilling rig is brought to the site. Once it is situated above the desired location, drilling can begin. Roustabouts work on the rig and handle many of the different elements of drilling.

Drill bits have sharp teeth that rotate to tear apart rock while the well is drilled. As the well gets deeper, lengths of 30-foot pipe are attached to the top of the drill. Each 30-foot section must be lifted above the last section into the sky and screwed onto the previous section. This is one of the reasons drilling platforms are very tall.

When drilling an oil well, the rock that is torn by the drill bit (called debris) does not come easily to the Earth's surface. As the hole gets deeper, debris can get in the way, blocking the hole. For this reason, drillers use mud to lift debris out of the well. Drilling mud originally was actual mud found on the drill site. Today, mud is a complex material specifically made for its purpose. Because it is so complex, mud is one of the biggest expenses in drilling.

Mud flow is controlled by the mud engineer. It is pumped down the hollow drilling pipe. It comes out near the drill bit, cooling the bit. The mud then carries debris up through the well as it is pumped, to be collected above ground. One of the reasons mud is so expensive is that it must be formulated with precise density. Since less dense materials float on top of more dense materials, the mud must have a greater density than the rock that is being cut. Drilling mud also keeps the formation, or walls of the well, from collapsing inward.

Once a well has been drilled to the depth of the oil reservoir, the workers move into the next stages—well completion and production. The drilling rig is removed from the site and the well is prepared to begin producing oil.

### Well Completion

After a well is drilled, it must be completed before it can begin producing. There are three main steps in the completion process. The first step is allowing oil into the well so that it can be brought to the surface. The second is making sure that water does not get into the well, and the third is keeping underground rock out of the well.

Completion is not done the same way for all wells. Deciding what to do depends on a number of factors, including the size and shape of the oil reservoir, the surroundings of the reservoir, and the kinds of rocks and oil the reservoir contains.

### DRILL PIPE



### ROUSTABOUTS



Image courtesy of StatOil

Oil is contained within rock formations. The nature of these formations affects the way oil is pumped from the ground. There are two characteristics that are very important to predicting how the oil will flow. The first characteristic is porosity. Porosity pertains to the gaps, or pores, between the grains in the rock where oil is stored. Permeability is the second important characteristic; it measures how many of those pores connect to each other. Knowing if the pores connect is important, since these connections are what allow oil to flow to the well. Even though a rock formation is very porous, if it has no permeability, the oil will be difficult to extract.

Most oil formations also contain water, or saturation, near or mixed in with the oil. Producers must be sure to separate this water out of the formation. They must also be sure to avoid contaminating nearby ground water, land, and underground aquifers.

The amount of pressure in a formation is another factor that is very important. Since oil extraction removes mass from the Earth, the stability of the reserve is something that must be considered. While some formations can maintain their shape when oil is removed, others cannot. These formations must be stabilized, allowing them to remain open for fluids to flow.



The last issue to be considered is how well the reserves are connected. Compartmentalization is a situation in which the oil from one part of the reserve cannot flow to another part of the reserve. There may be faults in the ground that disconnect the layers, or pores from one section may not be connected to other sections because of low permeability. There can also be streaks of other types of rock that the oil cannot easily pass through between the well and the oil, or there may be other barriers in the way of the flow.

Once all these issues are taken into consideration, completing the well may begin. To start completion, the well must be open so that oil can flow into it.

### Casing the Well

Drill pipe does not stay in the well after it is drilled. It is replaced with longer, wider casing pipe, which is used to line the well. Usually, casing a well begins before the end of the drilling process. Casing the top of the well occurs as the drill continues to dig deeper into the ground. The final and deepest casing is placed in the well after drilling is complete.

The rock around the well is crushed to allow the oil to flow freely. Shooting nitroglycerin and shattering the rock in the immediate area can crush the rock. The side of the well, or the casing, blocks oil from getting into the well itself. At the levels where oil is present, the casing is perforated to let oil flow. Perforating the casing is done by shooting a very thin, fast jet of gas to penetrate and perforate the casing.

### Cementing

Once casings are in place, cement is used to fill in the gap between the casing pipes and the well wall. Drilling mud is pumped out of the well as cement is pumped in. As the cement is pumped in, the casing is slowly rotated to create a better bond with the cement.

## Production

Once the wells have been completed, they can go into production. Production wells do not have the complex, above ground structures that are in place during drilling. Instead, the wells are capped with smaller units. Ideally, oil is extracted using natural drive, which means there is enough pressure in the well to move the oil and no pumping is needed. Wells with natural drive have christmas trees above ground. A christmas tree, in the petroleum industry, is a series of valves and gauges used to measure and control the flow and pressure of the well.

Other wells do not have enough natural drive to move oil out of the Earth. They must use pumps to lift the oil to the surface. Typically, this is done with a sucker-rod pump, sometimes called a horse head pump because of its shape. Using one-way valves underground near the oil formation, the pump draws, or sucks, oil to the surface. As the horse head pump above ground goes up and down, valves below lift the oil. Pumps may run for only a few hours each day to avoid distorting the way the fluids are distributed underground. Many wells produce only a few barrels of oil a day.

In a well that has a lot of pressure, a blow out preventer, or BOP, is used to avoid explosions. A BOP includes monitors to ensure the well is operating correctly and a set of controls that react to any unexpected pressure change. If there is too much pressure, the

**CHRISTMAS TREE**



**HORSE HEAD PUMP**



**OFFSHORE RIG**



man-made elements of the well could be forced out the top of the well or fire could occur.

To monitor a well's progress, comprehensive data logs are kept that track a number of different factors. Radioactive, electric, mechanical, and sonic tools are just some of the ways wells are studied. If monitors indicate unusual well behavior, engineers investigate and attend to the problem.

### Subsea Operations

In offshore operations, well completion and production are similar to onshore, but they take place below hundreds or thousands of feet of water. Well caps must be resistant to corrosion by saltwater and must be able to withstand the pressure deep in the ocean. Well operators do not regularly visit the ocean floor to check on the well caps. Instead, sensors are placed on the well caps so that the wells can be monitored from the platform. Advanced technologies such as Remote Operating Vehicles, or ROVERS, can make robotic repairs to the well by operators on the platform using remote controls.

The oil is piped to an offshore processing platform where it is combined with oil from other wells before being cleaned and sent to a refinery. There is a limited amount of space on an offshore platform to store new oil, so all of the operations must be carefully coordinated. Production supervisors oversee the entire operation of an offshore rig to make sure operations are moving smoothly.



## Cleaning the Oil

Once oil has been brought to the surface, it must be cleaned. Refineries have specific standards that they require suppliers to meet before they will accept the oil. Producers usually clean their oil on site, near the pump. If a producer has multiple wells near each other, there may be one processing facility for a number of wells.

Field processing is used to separate out oil, gas, and saltwater. All of these materials can come up through the well mixed together. The simplest way to separate out the different materials is in settling tanks. Oil from the ground is pumped into a tank through one pipe and allowed to settle. Each layer of oil, gas, and saltwater is then pumped out through its own pipe. The downfall of this method is that settling can take a long time.

Pressurized separators that have a higher capacity and separate more quickly can also be used. Inside these separators, pressure is used to collect liquids at the bottom, while oil and gas are piped out the side. Separators do a good job of separating oil and gas, but more processing is needed to remove all of the saltwater.

When oil and water are mixed together, they can be difficult to separate. This is true for household vegetable oil and tap water and it is true for crude oil and saltwater. Refineries require that the oil contain no more than one percent water.

To remove excess water, heat is applied with a heat-treater. The heat-treater causes the droplets of water that are suspended in the oil to come together, creating larger drops that can be more easily removed from the oil. Water-free oil is removed from the top.

## Shipping Crude Oil

Oil wells are located above oil-bearing formations, wherever they are found. Refineries are usually near oil consumption markets, though many are located near major oil producing areas as well. There are different ways to get the oil from well to refinery.

Much of the oil we use is shipped via pipeline. Oil pipelines move crude oil from oil platforms offshore in the Gulf of Mexico to refineries onshore. Pipelines can also move petroleum products between regions of the U.S. Pumping stations along the pipelines are located every 60 to 100 miles to keep the oil flowing.

A pipeline must be kept clean. To clean the inside of a pipeline, an instrument called a pig is used. This instrument is shaped like a bullet and scrubs the wall of the pipeline. More advanced pigs, called smart pigs, use cameras to monitor the pipe for flaws.

For longer distances, oil is put in tanker trucks or moved by sea on oil tankers. Crude oil produced in Venezuela, for example, is carried to the U.S. in oil tankers. This oil is off-loaded at a refinery to be turned into useful products. Oil tankers have two hulls, or shells, to help prevent oil spills.

In most cases when oil is shipped by tanker, the crude oil travels through both pipeline and tanker. One example is crude oil produced on the Northern Slope of Alaska. This oil field is very far north, near the Arctic Ocean. Instead of building a port to bring tanker ships into these treacherous waters, a pipeline was built to carry the oil to a more easily reached port in the southern part of Alaska.

After transportation by oil tanker or pipeline to a refinery, much of the crude oil is placed in storage facilities or tank farms. These large cylinders hold the crude oil until the refinery is ready to process it.

## OIL TANKER



## OIL PIPELINES



## Refining

### Distillation

In its crude form, petroleum is of little use to us. To make it into products we know and use, petroleum must be refined—separated into its many parts. Those parts are what we use to fuel our world. Petroleum is made of hydrocarbons. Hydrocarbons are chemical compounds containing only hydrogen and carbon. These two elements combine in different ways to make hundreds of different compounds that we use to make thousands of products.

To separate petroleum products, oil is refined. The first and most important step in the refining process is distillation. Distillation has been around since ancient times. Stills were set up by many cultures to produce alcohol. The first distillation of oil was done at the world's first oil refinery in Romania in 1856.

Distillation is the separation of substances based on their boiling range. Petroleum is not the only thing that is distilled. The chemical industry and the beverage industry also distill their products. Basic distillation follows the same steps regardless of what is being separated.

A mixture is heated. As parts of the mixture begin to boil, they rise as gases. These gases are captured in a fractioning tower. While the bottom of the tower is very hot, the temperature at the top of the tower is cooler. Trays are placed at different levels inside the tower. These trays have holes in them so that gases can pass through. But as the gas meets a plate that is cooler than the temperature of that gas, it condenses, or turns back into a liquid. The condensed liquid that forms on each plate is sent to a pipe. Each plate has its own pipe that carries only the liquids collected on it. The separated liquids move to other machines for further processing.

## OFFSHORE PRODUCTION PLATFORM



## STORAGE TANKS



There are a number of products that come from the refining process. Hydrocarbons with simple molecular structures have lower boiling temperatures. As the molecular structures become more complex, the boiling temperature increases—more energy is required to break the intra-molecular forces between the molecules, which allows for the phase changes.

Once distillation is complete, the light, higher value products are cleaned and put to use. Heavy, lower value products are subjected to additional processes to either extract higher value products or alter their chemical make-up to produce higher value products.

### Processing

These different parts are sent through chemical processing to be turned into useful products. There are three main types of processes. Cracking breaks long hydrocarbon chains into smaller ones. Unification combines small chains into longer ones. Alteration rearranges pieces of hydrocarbon chains to make different hydrocarbons.

Cracking can be done in a number of different ways. One method is thermal cracking. Thermal cracking uses very high temperatures to break apart long chains of hydrocarbons. This can be done using high temperature steam.

Cracking can also be done by heating the residue from distillation towers to very high temperatures until it separates into useful parts. This process is also known as coking, since the material that is left after all of the useful hydrocarbons are removed is coke, a hard, porous carbon material. Coke is used by heavy industry, such as iron and aluminum manufacturing.

Another way that long hydrocarbon chains are broken is through catalytic cracking. A catalyst is a material that increases the rate of reaction. Catalytic cracking is used to change heavy diesel oils into diesel oil and gasoline.

When smaller hydrocarbons are combined to make larger ones through unification, they usually undergo a process of catalytic reformatting, a process that converts naphtha into aromatics. Aromatics are cyclic hydrocarbons—meaning the carbons form a ring rather than the simpler straight chain of hydrocarbons. Aromatics are typically used to make chemicals and blend gasoline. The main by-product of catalytic reforming is hydrogen gas.

Alteration is the rearrangement of molecules in a hydrocarbon to create a more useful hydrocarbon. Usually this is done with

## Fractionating Tower

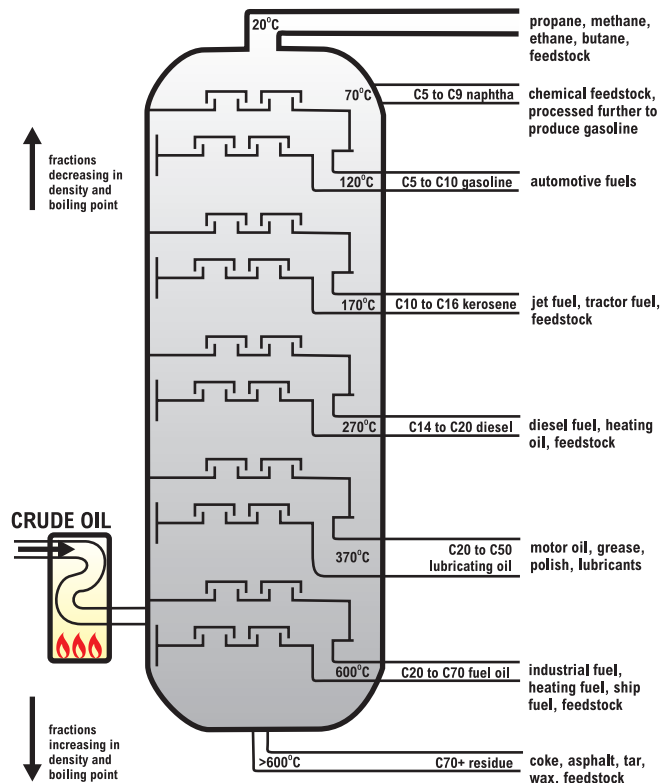

alkylation, a process in which hydrocarbons are mixed with a catalyst and an acid to create hydrocarbons that are high in octane. These high-octane hydrocarbons are blended into gasoline.

### Preparation to Market

Once all the products have been separated from the crude oil that went into the refinery, the products must be prepared to go to market. This last step is known as treatment. Gasoline, for example, is treated with additives that help engines operate more smoothly and burn cleaner.

From the refinery, different petroleum products make their way to a variety of places. Forty-two percent of every barrel of oil is made into gasoline, and 22 percent is made into diesel fuel. Another 10–15 percent is refined into other transportation products such as jet fuel, motor oil, and liquefied petroleum gases. Many of these products are produced by further chemical processing.

## Shipping Petroleum Products

After the refinery, most petroleum products are shipped to markets through pipelines. Pipelines are the safest and most cost effective way to move big shipments of petroleum. Gasoline is transported around the country through pipelines, most of which are buried underground. There are about 230,000 miles of underground pipelines in the U.S. It takes about 15 days to move a shipment of gasoline from Houston, TX to New York City.

Special companies called jobbers buy petroleum products from oil companies and sell them to gasoline stations and to other big users such as manufacturers, power companies, and large farms.



# Petroleum Based Transportation Fuels

Driving is an important part of Americans' daily lives. In fact, Americans drive their personal vehicles about 3 trillion miles a year. Commercial trucks drive 145 billion miles, public transit buses drive 2.3 billion, and school buses drive nearly 6 billion miles. There are a lot of vehicles racking up that kind of mileage—249,000,000 personal vehicles, 9,000,000 commercial trucks, 83,700 public transit buses, and 480,000 school buses.

## Gasoline as a Transportation Fuel

Today, gasoline is the fuel used by a vast majority of passenger vehicles in the U.S. There are about 249 million vehicles that use gasoline to travel an average of 12,000 miles per year. There are 162,000 fueling stations that provide convenient accessibility for consumers. The production and distribution infrastructures are in place. Most Americans consider gasoline the most sensible transportation fuel for today, even if it is not an ideal fuel.

Consumers are concerned about price fluctuations. During World War I, the cost of gasoline was about \$0.25 a gallon. The price of gasoline has averaged about \$2.00 a gallon in inflation-adjusted dollars for the last 80 years, until the shortages caused by Hurricanes Katrina and Rita, and the unrest in many oil producing areas, such as Iraq, Iran, and Nigeria. In 2010, the average cost for a gallon of gasoline was \$2.78.

## Diesel as a Transportation Fuel

Diesel fuel plays a vital role in America's economy, quality of life, and national security. As a transportation fuel, it offers a wide range of performance, efficiency, and safety features. Diesel fuel contains between 18 and 30 percent more energy per gallon than gasoline. Diesel technology also offers a greater power density than other fuels, so it packs more power per volume. Since 2004 diesel prices have been higher than gasoline prices. Diesel is more expensive due to higher refining costs and higher federal taxes. In 2011, the average retail price for diesel was \$3.80 per gallon.

Diesel fuel has a wide range of applications. In agriculture, diesel powers more than two-thirds of all farm equipment in the U.S. because diesel engines are uniquely qualified to perform demanding work. The construction industry also relies heavily on diesel fuel to operate heavy machinery. Diesel power dominates the movement of America's freight in trucks, trains, boats, and barges; 94 percent of our goods are shipped using diesel-powered vehicles. No other fuel can match diesel in its ability to move freight economically. In addition, it is the predominant fuel for public transit buses, school buses, and intercity buses throughout the U.S.

Diesel fuel is not just for large vehicles. There are five million diesel cars, pickups, and sport utility vehicles (SUVs) on the road today. A new generation of clean diesel cars, light trucks, and SUVs are now available and offer consumers a new choice in fuel-efficient

## Factors in Gasoline Pricing, 2010

In 2010, the average retail price for a gallon of regular grade unleaded gasoline was \$2.78. The biggest factor in the total price is the cost of crude oil that is used to produce the gasoline.

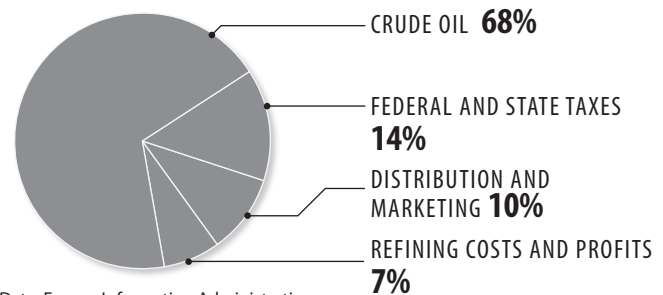

Data: Energy Information Administration

and low-emissions technology. Clean diesel is a proven technology that is clean, quiet, and fun to drive. Many new diesel options are available for car consumers in every state. Thanks to their inherent fuel efficiency, diesel engines also offer a viable and readily available strategy for reducing greenhouse gas emissions as they produce 20 percent fewer carbon dioxide emissions than gasoline vehicles. American drivers who purchase cleaner-burning diesel cars, trucks, and SUVs are eligible for similar tax incentives as purchases of gasoline-hybrid electric vehicles.

## Characteristics and Environmental Impacts of Gasoline and Diesel Fuels

Gasoline is a nonrenewable fossil fuel that produces criteria air pollutants—carbon monoxide, lead, nitrogen dioxide, ozone, particulate matter, and sulfur dioxide—when it is burned. Since the 1960s, stricter environmental standards have led to gasoline formulations and vehicle designs that have reduced vehicle exhaust emissions by 95 percent.

The Clean Air Act Amendments of 1990 mandated that reformulated gasoline be used in areas of the country that do not meet air quality standards, as well as reductions in nitrogen compounds (NO<sub>x</sub>) and volatile organic compounds (VOCs). More than a dozen different formulations of gasoline are now required by law in the U.S. Blending ethanol with gasoline was originally targeted in areas that did not meet air quality standards. Now, it is common place to find up to 10 percent ethanol blended into gasoline.

Significant progress has been made in reducing emissions from diesel engines. With new clean diesel technologies, today's trucks and buses are eight times cleaner than those built just a dozen years ago. As of 2010, new trucks and buses have near zero emission levels.



## Chemical Manufacturing

Petroleum goes into much more than just the tanks of our cars and airplanes. Petroleum is part of many of the products we use every day. It is well known that plastics are made from petroleum products, but that is only the beginning. Your toothbrush, toothpaste, shampoo, and even your contact lenses contain petroleum, as do carpeting, CDs, the ink in your pen, and medical devices such as prosthetic heart valves.

Chemical plants take refinery products and turn them into the products we use. There are many different kinds of chemical plants. Some are small and produce one or two items. Some are very large and produce a number of items. The largest plants can produce over 5 billion pounds of product each year. Large chemical plants operate all the time. They run 24 hours a day, every day of the year. Many of these plants are automated with new technology and need fewer people than in the past to run them.

## Plant Equipment and Processes

Cracking in a chemical plant is very similar to cracking in a refinery. Heat is used to break apart the chemical bonds of the hydrocarbon molecules in feedstocks. Feedstocks are the raw materials used to make products in chemical manufacturing plants.

### Boilers and Furnaces

Both boilers and furnaces are important parts of chemical plants. Often feedstocks are brought to a chemical plant in solid form, such as powder or pellets. To work with these materials, they must be heated and melted into liquids or sometimes gases.

### Cooling Towers

Cooling towers are used to return the water used in chemical processing back to normal temperature before it is returned to the river or lake from which it was taken. To do this, water is sent through a maze-like structure that allows as much air as possible to come into contact with the water. Gravity pulls the water down through this maze, cooling it as it goes.

The air inside a cooling tower heats up as it comes into contact with the warm water being fed into the tower. The warming air rises, collecting a tiny bit of water vapor in the process, and is released from the top of the tower. As you drive by a chemical plant, you can sometimes see a cloud of water vapor rising from the cooling tower.

### Heat Exchangers

Heat exchangers are devices that can speed up production and cut down on the need to process waste heat at the same time. Heat exchangers use fluids that contain waste heat, or heat that is no longer useful from a previous step, to heat materials that must be warmed in another step.

Heat exchangers are large pipes with smaller pipes inside. The small pipes carry cool liquids that need to be heated. The small pipes do

## Products Produced From a Barrel of Oil, 2010

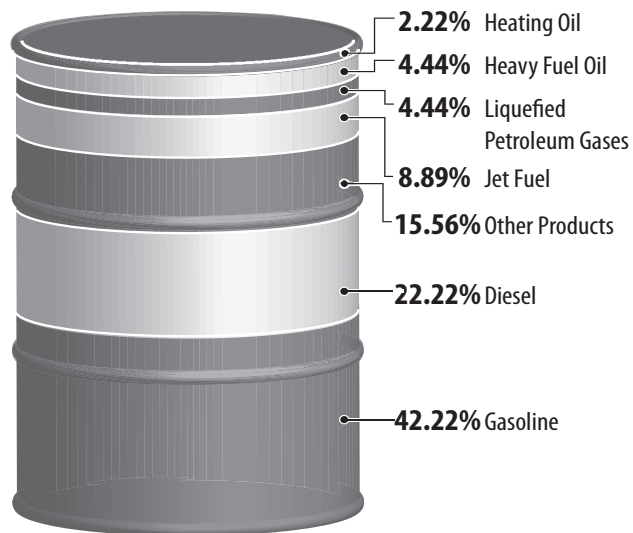

Data: Energy Information Administration

### FURNACE



### Heat Exchanger

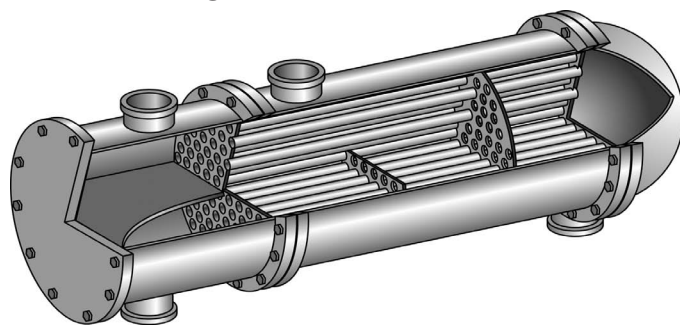

not completely fill the large pipes, and the space around the small pipes is where the waste-heat fluid (liquid or gas) flows.

As the cool liquid and the hot fluid flow past each other, heat is transferred from the hot fluid to the cool liquid. At the end of the heat exchanger, the cool liquid has warmed in preparation for its next step. The hot fluid has cooled and requires less processing.

### Wastewater Treatment

Processing chemicals can use large quantities of water. Water is present in nearly every step. Boilers, cooling towers, and heat exchangers all use water. To ensure that the water leaving the plant is as clean as the water coming into the plant, wastewater treatment facilities are located on site.

### Laboratory

One important part of a chemical plant is the laboratory. Chemists constantly monitor the product at each step to make sure it meets the required specifications. If the chemistry is not just right, plastic bags could be too weak to hold groceries or nylon thread too brittle to sew. Chemists also monitor waste products to make sure the land and water is not being polluted.

## Loading Station

Once the final product is complete, it is stored in a warehouse or storage tank, depending on the type of product. When needed, the product is taken from the storage facility to a loading station to be transported to market or to another chemical plant for further processing. Depending on the product, it may be transported by road, rail, air, water, or pipeline.

## Transportation

Refineries and chemical plants are located all over the country and feedstock is often moved long distances between the two. Sometimes, chemicals are moved in small 50-pound bags or 400-pound drums. Feedstocks that must be transported in large quantities may be moved by barge, ship, or pipelines, which can carry larger quantities of product.

## Products

To get the products that are familiar to us, feedstocks must be processed. Different products have different steps that are needed. Many products are made from more than one feedstock, which are combined in different ways to produce a variety of products.

There are two general types of chemicals produced from petroleum that are used to create most everyday items—aromatics and olefins. Aromatics are a group of petrochemicals with a distinctive sweet smell that are characterized by ring structures, and are produced in refineries and petrochemical plants. The most common aromatics are benzene, toluene, and xylenes.

Aromatics are used for chemical production or as high-octane components for gasoline blending. Aromatics are used to make plastics and polymers. These go into products such as paint, textiles, building materials, and leather alternatives.

Olefins are a class of hydrocarbons recovered from petroleum that contain one or more pairs of carbon atoms linked by a double bond. Typical examples include ethylene and propylene. Olefins are obtained by cracking petroleum fractions at high temperatures. Another word for olefin is alkene.

The simplest olefins—ethylene, propylene, butylene, butadiene, and isoprene—are the basis of the petrochemicals industry. They are used to produce plastics, industrial solvents, and chemicals that are used in other applications. A number of familiar products come from these petrochemicals, including plastic bags, paint, tires, and plastic bottles.

### Benzene

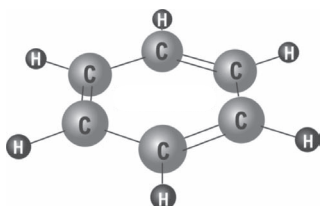

### Ethylene

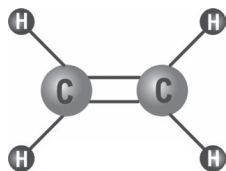

## Sphere Storage Tank

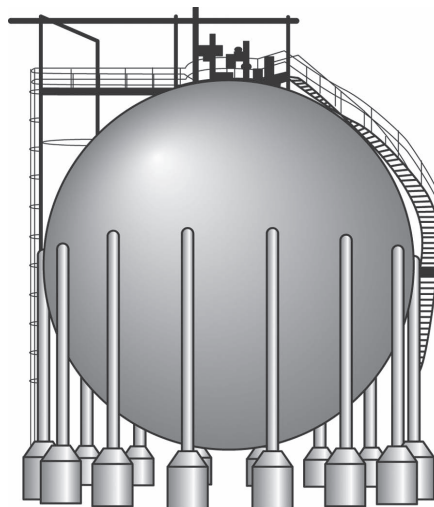

## Products Made From Petroleum



Lipstick



Action figures



Rubber bands

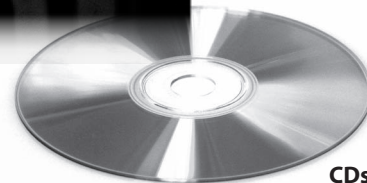

CDs



Tape



Pen

## Health and Safety

Worker health and safety are top priorities in all process industry facilities. To help ensure that workers are safe on the job, all manufacturing plants follow OSHA (Occupational Safety and Health Administration) rules and guidelines.

In many work settings, for example, OSHA guidelines require that workers wear hardhats, ear protection, eye protection, or other safety gear.

Chemical plants are continuously making their operations as safe as possible. Spill kits are located throughout a plant so that if there is a spill, clean-up can be accomplished quickly. Plants also work hard to replace any materials used in their processes that are toxic with alternatives that are safer for workers and for the environment.

One safety feature at a chemical plant is the fire pond. A pond of water is kept on site ready to be pumped if a fire were to erupt. There are usually a number of ponds scattered around each plant site so that one is never far away if it is needed. Since fire pond water does not need to be as clean as the water we use in our everyday lives, storm water is often collected to fill the ponds.

## Into the Future

As the demand for petroleum products grows and the issues become more and more complex, energy companies are using advanced technologies to design and deliver next generation fuels and products. The skills used by all workers in the petroleum product industry are transferable to these new technologies. New opportunities are emerging every day.

Consumers can make a real difference by recycling petroleum-based products and buying products that conserve energy.

To take a tour of a chemical plant, go to the Center for the Advancement of Process Technology's Virtual Chemical Plant at <http://capt.com.edu/virtualchemplant/>.

## OIL WORKER

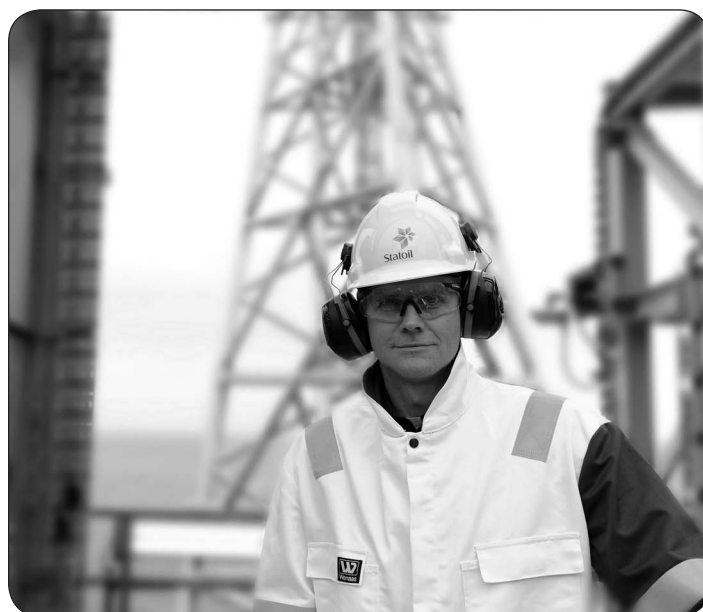

Image courtesy of StatOil





# Careers in the Oil and Gas Industry

The oil and gas industry offers a variety of careers for individuals to work at its refineries, chemical plants, or on exploration and production onshore/offshore facilities. The following are an example of some of the career options available:

**Process Technicians** - members of a team of people that control, monitor, and troubleshoot equipment and focus on safety and environmental considerations.

**Instrumentation Technicians** - maintain, calibrate, adjust, and install measuring and control instruments necessary to ensure the safe, efficient operation of equipment.

**Electricians** - read blueprints that show the flow of electricity and maintain and repair the electrical and electronic equipment and systems that keep the facilities up and running.

**Machinists** - install, maintain, repair, and test rotating mechanical equipment and systems.

**Geologists** - explore the nature and structure of rock layers to piece together a whole picture of the subsurface in order to determine the best possible places to drill for oil and natural gas.

**Petroleum Geologists** - gather, process, and analyze seismic data and well data in order to locate drill sites for their companies.

**Geoscientists** - study the composition, structure, and other physical aspects of the Earth and are involved in exploration and production of oil and natural gas.

**Petroleum Engineers** - play a key role in determining the reservoir capacity (how much oil it might hold) and productivity (how much it produces) to design systems that move the petroleum from the wells (production process) through refining, where it gets cleaned up and converted into the energy we use.

**Chemical Engineers** - design chemical plant equipment and develop processes for manufacturing chemicals and products like gasoline, detergents, and plastics.

**Mechanical Engineers** - deal with the design, manufacture, and operation of the machinery and equipment used to improve oil drilling, and the processing of petroleum or chemical products.



Image courtesy of Shell



Image courtesy of Shell



# Oil and Gas Career Game

Imagine you are a drop of oil or a molecule of natural gas. Cut out the game pieces to the right and roll a die to follow the path from the ground to market. Along the way, you will meet many people who help you on your journey.

## GAME PIECES





# Q&A

NEED GETS TO KNOW INDUSTRY PROFESSIONALS

## Adam Bell

Adam Bell is a Technical Engineer at Schlumberger. He started out as a Field Engineer Trainee with a Bachelor's degree in Chemical Engineering. Schlumberger develops their Field Engineers through several steps of operational and technical schools combined with field work in advance. He participated in a Co-Op/Internship program in college, which he felt was especially useful in preparing for this challenging field.



### TELL US A LITTLE ABOUT YOUR JOB AND WHAT YOU DO?

I focus on developing our laboratories, facilities, and engineers in the Horseheads, NY district. I began my career working on field crews in South Texas, and moved into managing daily operations of well stimulation crews in Arkansas, Oklahoma, and New York. That included hiring and developing field crews, coordinating people, materials and equipment, and interfacing with clients both in preparation and following up on completed treatments.

### HOW DID YOU DECIDE TO GO TO WORK IN THIS FIELD?

I have always been interested in math and science from a young age, which led me to wanting to become an engineer.

### WHAT IS A TYPICAL DAY AT WORK LIKE FOR YOU?

When I worked in the field, I was at work before 5 a.m. preparing paperwork and then briefing the crew on the day's job. From there I would lead a convoy of up to 20 trucks to a well-site where we would rig up the equipment, pump the job, rig the equipment down, and move to the next well-site. All of this would happen before 7 p.m. that same day. Now, my day begins at the office at 8 a.m. and usually ends around 7 or 8 p.m.

### COULD YOU DO YOUR JOB ANYWHERE IN WORLD?

The majority of well cementing and stimulation is performed on the oil and gas wells drilled in the United States. This covers a significant portion of the U.S. from California, the Rocky Mountains, Texas, Arkansas, Oklahoma, Louisiana, all the way to the Appalachian Mountains.

### WHAT IS THE MOST CHALLENGING PART OF YOUR JOB?

The "24/7" nature of this fast-paced industry pushes everyone involved to their limit. To ensure that risks are managed and the correct decisions are made to perform the job safely and correctly is a constant challenge. In the Northeast part of the United States, one of the key challenges is to educate the public about our industry as well as ensure that all operations are conducted in accordance with established best practices in order to justify the public's trust.

### ANY ADVICE FOR YOUNG PEOPLE CONSIDERING A CAREER IN THIS INDUSTRY?

Be ready to work harder than you ever thought was possible. You will always continue to learn in an industry that will always be challenging and changing at a dramatic pace—you will never be bored. If you are considering a career in this industry you cannot be afraid to get your hands dirty!

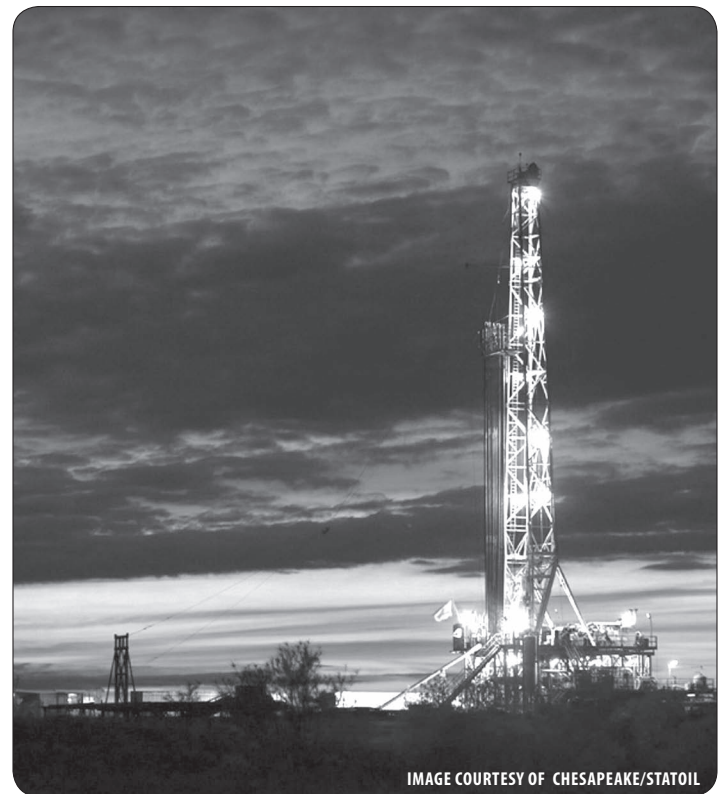

I have been able to see the sun rise and set across the countryside of America ...

### ANY OTHER COMMENTS ABOUT PURSUING A CAREER IN THIS FIELD?

I have been able to see the sun rise and set across the countryside of America and have been able to work with an incredibly diverse, multi-national workforce. Abundant energy resources have enabled dramatic improvements in quality of life and advances in technology can never be predicted and should not be underestimated. Ensuring safe, reliable, and affordable energy for future generations is not only one of the greatest engineering challenges of today but also of primary concern for our society's future.

# Q&A

NEED GETS TO KNOW INDUSTRY PROFESSIONALS

## Pat Bond

Pat Bond is the Vice President of Sales for Drilling Tools and Remedial (DTR) at Schlumberger. Before and after graduating from The University of Texas with a B.S. in Petroleum Engineering, Mr. Bond spent years in the field working on rigs and running tools, building his understanding of the business literally from the ground up. That, along with his engineering degree, led to a technical career where he travels the world giving technical support and presentations.

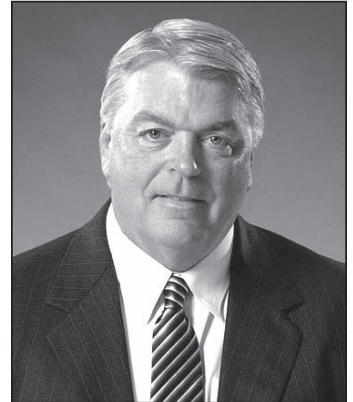

### HOW DID YOU DECIDE TO GO TO WORK IN THIS FIELD?

Growing up in Houston I was always around people in the energy business. I found the people to be daring and entrepreneurial (also known as “Wildcatters”) as they were taking risks and either hitting it big and driving fancy cars or going broke trying. That swashbuckling attitude was what first attracted me to the industry. From there I got hooked on the whole process of oil and gas extraction. We all use and depend on petroleum products so I figured the long term career prospects were good.

### WHAT IS A TYPICAL DAY AT WORK LIKE FOR YOU?

Every morning I wake up thinking about how to get more business for my company. That includes calling on customers, evaluating new tools and processes that will assist our sales people, meeting with internal partners to discuss delivery, people, training, finances, and legalities. Fundamental questions we ask ourselves every day are “What do our customers need? What keeps them awake at night?” If you can solve those questions, and prove it, then sales will come.

### HOW HAS YOUR FIELD CHANGED IN THE LAST 5-10 YEARS?

We are running tools in markets that did not exist 5-10 years ago. These new tools and markets now make up a large part of our annual revenue. The trick is adjusting to those needs and markets in time to capture a significant part of the business. If you stay still you will get run over in this industry. I think of it as—there are people who run the business and people who change the business. We always need a proper balance of people running today’s tools in today’s markets while we have people looking ahead at new tools and new markets.

### WHAT IS THE MOST REWARDING PART OF YOUR JOB?

Like most competitive people I like to win. Gaining enough trust from our client so that they reward us with business is a fantastic feeling. Mentoring young or new team members is also very gratifying.

### WHAT ARE SOME IMPORTANT ATTRIBUTES ONE MUST HAVE FOR THIS JOB?

Knowledge of the subject area and learning the art of public speaking have helped me tremendously in my role today. Obviously you never stop learning as I continue to take technical and leadership training classes to this day. I also have a personal objective on my annual performance review to take a certain amount of training classes every year.

### WHAT CHALLENGES DO YOU FACE IN THE INDUSTRY?

Government regulations and negative public perceptions are constant challenges. In the aftermath of the oil spill in the Gulf of Mexico, these challenges have been magnified and of course in some ways justifiably so. But, regardless of perceptions and regulations the world still needs cars, trucks, planes, trains, ships, plastics, fertilizers, electricity, pharmaceuticals, cell phones, etc, made possible by petroleum products. I always wonder if the people who are down on the energy business know how much we contribute to society. And as a side note—I’m not sure how much more organic you can get than oil and gas—it comes from the EARTH.

### WHAT ARE SOME BENEFITS TO WORKING IN THIS INDUSTRY?

Besides working with technology that rivals the space industry, there is camaraderie in this business that makes the whole thing fun to be in. On the technology side—think about drilling where the working platform is on water 2 miles above the sea floor and drilling a hole that is another 5 miles in length and hitting a target that is the size of a football field while dealing with all the challenges of pressure, temperature, and mechanical issues. The level of technology is actually quite amazing and really should be seen to understand.

### WHAT ADVICE WOULD YOU GIVE TO YOUNG PERSON WHO IS INTERESTED IN WORKING IN THE OIL AND NATURAL GAS FIELD?

I understand that there are some negative feelings about the energy business and relatively few people outside of the business truly understand what happens to get oil and gas out of the ground. I would say to anyone to take some time to understand the process and technology of oil and gas extraction and make up your own mind—don’t let outsiders who don’t know the business influence your decision.





Many people in the oil and gas industry, such as Mr. Bond, begin their careers in the field working as roughnecks or roustabouts before moving their way up through a company.

For those who are interested in a career in the energy industry there are plenty of opportunities for high energy people with or without a college degree. If in college, focus on math and science and take job shadowing and internships. These experiences and relationships will only help your career. If college is not in your plans, that's OK. Be flexible on where you want to live and work. There are oil and gas basins all over the world and all of them need good solid people to bring the oil and gas to surface, process it, and get it to market.

For any person interested in a career in the oil and gas business I would say keep your integrity. It's really the only thing anyone really has. Who wants a smart person that you can't trust? Say what you are going to do, then do it. This business is all about trust. There are always safety and financial risks in this business and trust is a necessity for a successful career.

#### **ANY OTHER COMMENTS ON CAREER OPPORTUNITIES IN THE OIL AND GAS FIELD?**

After nearly 30 years in this business I still wake up excited about my job. There are always new technologies, new markets, and challenges that keep this a very dynamic industry. On top of that, the industry is very social with plenty of technology conferences, industry associations, ties to universities, and affiliations with



charitable associations that constantly bring you in contact with customers and peers. I obviously have a very biased opinion, but I honestly don't see how people work in any other industry.

# Q&A

NEED GETS TO KNOW INDUSTRY PROFESSIONALS

## Galen Cobb

Galen Cobb is Vice President of Industry Relations for Halliburton and is responsible for the company's industry relations and global activities. As a graduate of Oklahoma Christian University with a degree in business, Mr. Cobb has been with Halliburton for over thirty-five years. Mr. Cobb serves on numerous industry, trade association, and civic boards throughout the industry, and was recently awarded the Spindletop Don E. Waggener-Butch Griffin Award as well as the NEED Distinguished Service Award.



### TELL US A LITTLE ABOUT YOUR JOB AND WHAT YOU DO.

After working for Halliburton for almost 35 years I have had many different positions with the company. Currently I have broad responsibilities that include managing the company's industry relations, energy trade policy issues, executive client relations, and trade organizations oversight. Really my position is all of these things rolled into one. I am also very involved in our education component, which allows me to work with many K-12 schools and improve our relations with the future of our industry.

### HOW DID YOU DECIDE TO GO TO WORK IN THIS FIELD?

Thirty-six years ago I was out of college, looking for a job, and found Halliburton. I started as most people do in this industry, at an entry level position doing field service work, export shipping, then working up to export sales. I have had various executive management positions in operations, marketing, and sales and business development. I was also the Director CIS in China with oversight in establishing Halliburton's presence and operations in these emerging markets.

### WHAT IS A TYPICAL DAY AT WORK LIKE FOR YOU?

There is a lot of variety in my daily work schedule. Serving on 15 Boards and 32 Industry Committees I find myself traveling a lot, and doing many breakfasts, luncheons, and dinners that are all related to our industry. I have been fortunate enough to be able to spend a lot of time in Houston, Texas where I reside as well as traveling extensively throughout the world. I also spend many days working with schools and education programs to improve our educational institutions as well as our industry.

### WHAT IS THE MOST REWARDING PART OF YOUR JOB?

The opportunity to meet such a wide variety of people is very enjoyable. I also feel that getting to know the different industry trade issues and working through those with various different people makes my job exciting. Another very enjoyable part of my job is focusing on enhancing our education programs. The future of our industry is in our youth, and educating them to be successful not only in their careers but to make a difference in their country.

### WHAT CHALLENGES DO YOU FACE IN THE INDUSTRY?

The biggest challenge I face in our industry is the mindset and perception of the oil and gas industry. It is very important that we keep the price of our resources at an affordable range for our country. The oil and gas industry really affects our economy, which in turn has a huge influence on the future. We are very big fans of

renewable energy sources, and work with those industries as well. Everyone that is associated with energy is on the same team, and we enjoy working together. Oil and gas is not something that can go away quickly, and it is something in which the U.S. is the leader. Focusing on needing every energy source and producing them in a clean manner are the biggest challenges we face. I am a big proponent of the facts, which The NEED Project does a super job of delivering to schools and institutions across the country.

### WHAT ARE SOME BENEFITS TO WORKING IN THIS INDUSTRY?

Our industry has some tremendous benefits. The oil and gas industry is going to be very strong throughout the next 30, 40, even 50 years. The upward mobility of this career path is endless. If you have talent and a willingness to learn and get better, you will advance very quickly. No matter what specific part of the energy industry you work in, if you are willing to do what it takes, you will have wonderful personal, financial, and industrial benefits.

### WHAT ADVICE WOULD YOU GIVE TO A YOUNG PERSON WHO IS INTERESTED IN WORKING IN THE OIL AND NATURAL GAS FIELD?

Pay your dues. Be willing to get dirty, start in the field, and work your way up. The industry is always looking for leaders that are looking to manage parts of the job, and increase their knowledge and duties. For a very fast payback on your education, a technical degree is the best. Getting your engineering degree and being willing to learn four to five years of technical work, you will really be set in a wonderful career in a great industry. I would also like to encourage young people to give the oil and gas industry a fair evaluation and not exclude it from the decision of a career. The demand for young people in our industry is huge, and it is like that every year. I believe Halliburton hired close to 15,000 people last year and are going to need even more in the next year or so.

### ANY OTHER COMMENTS ON CAREER OPPORTUNITIES IN THE OIL AND GAS FIELD?

Halliburton has started some Petroleum Academies in Houston area schools. This takes juniors and seniors interested in this industry and allows them to earn advanced credits to apply to college when they graduate high school. This also gives students the opportunity to receive mentoring from professionals. In the summer they spend three weeks at Halliburton and other companies and get to see a live look at the industry, career outlook, and physically get to work in the field and simulate all aspects of this career. I am also a huge fan of The NEED Project and the information they provide as well as the opportunities.



# Q&A

NEED GETS TO KNOW INDUSTRY PROFESSIONALS

## Ashley Lantz

Ashley Lantz is an Operations Engineer for Encana in Colorado. She graduated with a Bachelor of Science in Petroleum Engineering from the Colorado School of Mines.



### TELL US A LITTLE ABOUT YOUR JOB AND WHAT YOU DO.

I work for our exploration team as an Operations Engineer. In our exploration group, operations engineers are involved in all aspects of well planning for new areas. We work with state and local officials to plan well locations, design and complete wellbores, and evaluate well performance when the wells begin producing. I spend one to two weeks per month in the field and at the well site during the drilling and completion phases. Field work is critical to the success of projects and the development of my engineering skills.

### WHAT IS THE MOST REWARDING PART OF YOUR JOB?

I enjoy being involved in both the project planning and execution phases. It is exciting to be able to start with designing a project on paper and to also have the opportunity to implement designs and actually see the work take place.

### WHAT IS THE HARDEST PART OF YOUR JOB?

One of the biggest hurdles is to anticipate future challenges and successfully design projects that mitigate or avoid those potential issues.

### COULD YOU DO YOUR JOB ANYWHERE IN THE COUNTRY?

Our industry has both location and work schedule flexibility and as a result, engineers have many career path choices. Depending on the company, operations engineers typically have the opportunity to work from either corporate or field offices. Operations engineers also have flexibility in work schedules such as rotational work within the United States and throughout the world.

### WHAT TYPE OF TRAINING OR EDUCATION IS REQUIRED?

Obtaining an engineering position at Encana required a Bachelor of Science degree; specifically I received a Bachelor of Science in Petroleum Engineering from the Colorado School of Mines. Even though I pursued a degree specific to the energy industry, engineers of other disciplines also qualify for various positions. In addition, many engineers elect to pursue graduate degrees; however, that is not required in most engineering disciplines.

While in college, I took advantage of the many internship opportunities our industry provides. I was fortunate to work three different summer internships in college. This was an excellent way to gain experience and find employment after college. My internships helped me secure a full time position with Encana early in my senior year of college.



Much of Ashley Lantz's time is spent in the field at drilling sites.

# Q&A

NEED GETS TO KNOW INDUSTRY PROFESSIONALS

## William Pike

Dr. William Pike is currently a consultant within NISC, an IBM company, and works under contract in the National Energy Technology Laboratory (NETL), a division of the U.S. Department of Energy. Dr. Pike holds a Ph.D. from the University of Aberdeen. He has contributed to several books on oil and gas technology and energy economics and has authored technical papers on offshore drilling and production.

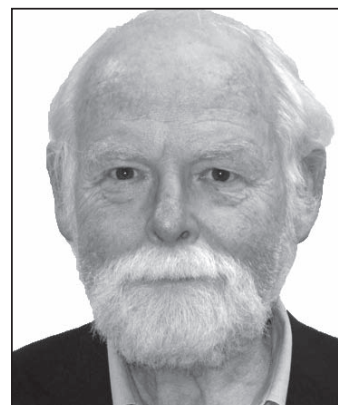

### TELL US A LITTLE ABOUT YOUR JOB AND WHAT YOU DO.

I am an employee of IBM. I work under contract to the National Energy Technology Laboratory (NETL), a division of the U.S. Department of Energy. The Department of Energy conducts and funds research and development for the oil and gas, and other energy, industries through NETL. My work is undertaken, primarily, for the Strategic Center for Natural Gas and Oil (SCNGO) within NETL. SCNGO's mission is to conduct research that contributes directly to the enhancement of the nation's oil and gas supply in an environmentally safe manner.

### HOW DID YOU DECIDE TO GO TO WORK IN THIS FIELD?

This field of work found me. A friend called to ask if I knew anyone who might be interested in the job. After he described it, I determined I was. The job allows me to bring my 20 odd years of experience in oil and gas exploration and production, plus a number of years as editor of technical publications, to bear on research and development that I believe is vitally important for our nation.

### WHAT IS A TYPICAL DAY AT WORK LIKE FOR YOU?

In a typical day I will work at three to four tasks. These generally revolve around assessing research and development programs, enlisting acquaintances in the industry to review NETL programs, advising NETL on various issues, and managing an outreach program to inform the industry and the public of the accomplishments of the NETL research and development program. To do this, I spend a good deal of time on the telephone and on e-mail.

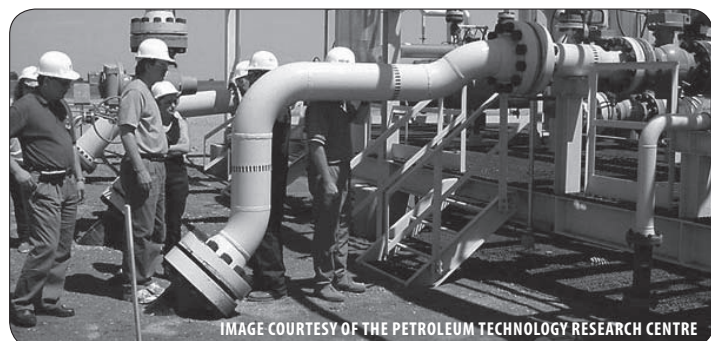

IMAGE COURTESY OF THE PETROLEUM TECHNOLOGY RESEARCH CENTRE

Some of Dr. Pike's work with NETL focuses on researching new carbon capture and storage technologies.

### WHAT TYPE OF TRAINING OR EDUCATION IS REQUIRED?

The job I do requires at least a bachelor's degree, preferably in engineering or the geosciences. More importantly, it requires a great deal of experience on the ground in the technical sector of the oil and gas industry.

### WHAT IS THE BIGGEST CHALLENGE THAT YOUR INDUSTRY FACES?

I face the same challenge that everyone in our industry faces - the provision of energy to sustain and build the nation's economy and infrastructure in a prudent, safe, and environmentally friendly manner.

### WHAT ARE THE BIGGEST BENEFITS TO WORKING IN YOUR INDUSTRY?

The primary benefit of working in the upstream oil and gas industry is getting to work with people you like and respect. The upstream industry is global but the workforce is not large by most industry standards. Over the course of your career, you make lasting friendships around the globe. The second benefit that I have found in this industry is the knowledge that what you are working on is important to the entire global community.

### WHAT ARE SOME OF THE OPPORTUNITIES YOU HAVE HAD THROUGHOUT YOUR CAREER?

Some opportunities that I have had include the ability to work at jobs I enjoy, the opportunity to advance in these jobs, and most importantly to me, the opportunity to live in foreign countries with my family and travel a good bit of the globe.

### ANY OTHER COMMENTS OR ADVICE FOR THOSE INTERESTED IN A CAREER LIKE YOURS?

Despite a lot of rhetoric floating around today, the oil and gas industry will be a healthy industry for many decades to come. If you are interested in working in the industry, the first key to success is education. The technologies we use are extremely sophisticated. A bachelor's degree in a technical subject related to the industry is the entry card for a successful career. Past that, creating a successful career requires a lot of flexibility. There will be a lot of moves, a lot of travel and a lot of 16-18 hour days as you build your career in the industry. In the end however, it is worth it!

**FORMATION**

**FACTS**

**TECHNOLOGIES**

**CHALLENGES**

**EXPLORATION**

**CAREERS**

**FACTS**

**GEOLOGY**

**TECHNOLOGIES**

**CHALLENGES**

**PRODUCTION**

**CAREERS**

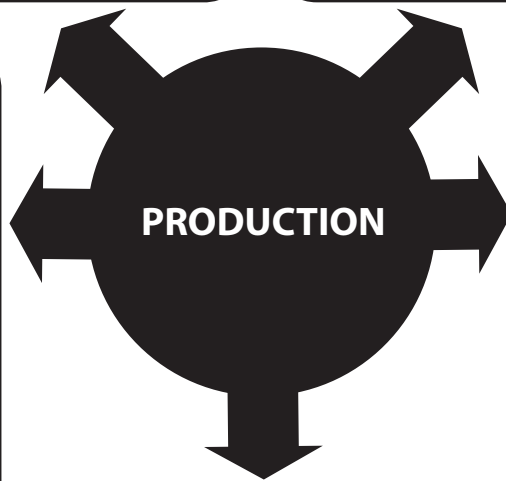

**FACTS**

**PROCESSES**

**TECHNOLOGIES**

**CHALLENGES**

**REFINING**

**CAREERS**



**FACTS**

**PROCESSES**

**TECHNOLOGIES**

**CHALLENGES**



**CAREERS**

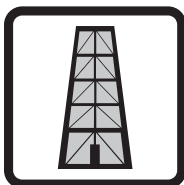

# Jigsaw Role Questions and Presentation Questions

## Exploration: Geologist

---

1. Why is an understanding of fossil fuel formation helpful in locating oil reservoirs?
2. What geological characteristics are associated with oil reservoirs?
3. What technologies are used to locate oil reservoirs?
4. What types of careers are available in oil exploration?

## Production: ROVER Operator

---

1. What technologies are used to drill for oil?
2. What physical characteristics of rock formations are important when drilling for oil?
3. How does offshore drilling differ from drilling on land?
4. What types of careers are available in oil production?

## Refining: Lab Technician

---

1. What are the important characteristics of hydrocarbons?
2. What are the processes involved in refining crude oil?
3. What products come from refining crude oil and how are they used?
4. What types of careers are available in oil refining?

## Manufacturing: Process Technician

---

1. What are feedstocks and how are they used?
2. What equipment and processes are involved in chemical manufacturing?
3. What are some of the important products of chemical manufacturing?
4. What types of careers are available in chemical manufacturing?

## Transportation: Pipeline Inspector

---

1. What types of transportation are used in oil production?
2. What are the hazards of transporting petroleum and its products?
3. How are pipelines maintained?
4. What types of careers are available in petroleum transportation?

## Consumer

---

1. What petroleum products do average Americans use every day?
2. Where does the U.S. get its crude oil?
3. What are current economic trends in the oil industry?
4. What are the environmental impacts of petroleum production and consumption?

## Presentation Questions

---

1. What are the advantages of using petroleum?
2. What are the disadvantages of using petroleum?
3. Does the use of petroleum provide more benefits or risks to society?
4. How would a sharp increase in the price of crude oil affect the standard of living in the U.S.?
5. What can consumers do to ensure that future generations will receive the benefits of petroleum products?

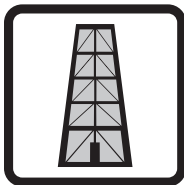

## INTRODUCTION ACTIVITY

# Formation of Oil and Natural Gas

Activity courtesy of SPE

## Oil and Natural Gas Formation | REFERENCE: OIL AND NATURAL GAS BOOK PAGES: 16-21

### Materials

- 8 ½" x 14" Sheets of paper (one per student)
- Colored pencils and markers

### Procedure

1. Give each student an 8 ½-inch x 14-inch sheet of paper. Instruct the students to divide the paper into three equal parts. Label the sections: Scene 1, Scene 2, and Scene 3.
2. Have students clear everything off of their desks except for colored pencils and the piece of paper. Tell the students that their work will be displayed in the halls of the school. They will be listening to a story and drawing their explanation.
3. Read the following story to the students. Tell the students to listen carefully. They can draw while you are reading or at the end of each scene. Allow students to decide what way is best for them.

## Scene One

570 million years ago—during a period known as the “Paleozoic Era” [pey-lee-uh-zoh-ik]—a large sea covered the area we now recognize as the southern part of the United States. In this sea lived a vast number of microscopic plants and animals called plankton. This microscopic plankton drifted on or near the surface of the water and became so numerous that it could actually be seen with the naked eye. Throughout the Paleozoic Era the sea was also alive with trilobites, corals, crinoids, brachiopods, and many other plants and animals that evolved over millions of years. A trilobite was a strange-looking little creature. Small grooves divided its body and hard-segmented shell into three vertical parts. A semicircular shield covered its head. Coral, which still exists today, came in many different sizes, shapes, and colors. The coral polyps were simple animals that were able to take calcium out of saltwater and convert it into a rock-like shelter in which they lived. Crinoids anchored themselves to rocks on the sea floor with a root-like structure that supported a stalk or column topped by a cup-like cavity, which formed a protective case for a flower. Brachiopods were clam-like animals. Their two-piece dorsal and ventral shells enclosed and protected their soft body parts. Due to their ability to reproduce quickly, the plankton, along with other sea life, were abundant. As these carbon-containing organisms went through their extremely short life cycles and died, their remains sank to the deep sea floor and became covered with the mud, sand, and sediment from the eroding mountains and surrounding areas. Because they were buried so quickly on the deep sea floor, the plankton and other sea creatures lacked oxygen, which is necessary for decay or decomposition. Draw a picture that shows this scene on the first section of your paper.

## Scene Two

320 million years passed, and layers of sediment on the sea floor became thousands upon thousands of feet deep. These layers were filled with dead plankton, fossilized sea creatures, and eroded rock. During the time period known as the “Mesozoic Era” [mez-uh-zoh-ik], dinosaurs began to roam the Earth and swim in the sea. More than half of the great sea had disappeared because of evaporation, earthquakes, and the filling and layering of sediments on the sea floor. This heat and pressure was responsible for changing the dead organic material into hydrocarbons (substances containing hydrogen and carbon) and causing the remaining inorganic material to change into sedimentary rock. Draw a picture that shows this scene on the second section of your paper.

## Scene Three

250 million years later brings us to present day—the “Cenozoic Era” [see-nuh-zoh-ik]. People now walk the Earth and the dinosaurs have long since disappeared. Erosion and other sediments have now completely filled the ancient seas. The heat and pressure have formed many layers of sedimentary rock, and deep source rock—rock where oil and natural gas form. Much of the water that was in the sea is now in the pore spaces of the sedimentary rock. The remaining water evaporated or was pushed into areas where seas or oceans now exist. Over millions of years, temperatures ranging from 150-300 degrees Fahrenheit (66-149 degrees Celsius) have “cooked” the organic materials causing a complex chemical change, creating hydrocarbons called oil and natural gas. These hydrocarbons, also known as fossil fuels, have been discovered in Texas. Can you picture this scene? Draw a picture that shows this scene on the third section of your paper.

As you finish the last scene, keep in mind that there are several theories concerning the formation of oil and natural gas. What you have just heard and drawn is the most widely accepted scientific theory.

## Teacher Information

Oil and natural gas together make petroleum. Petroleum is a mixture of hundreds of different hydrocarbons—molecules containing hydrogen and carbon—that exist sometimes as a liquid (crude oil) and sometimes as a vapor (natural gas). Hydrocarbons are typically made from the remains of tiny sea plants and animals that died and were buried on the ocean floor for millions of years. Layer upon layer of the plant and animal remains built up. This pressure combined with heat from the Earth's processes slowly “cooked” the plant and animal remains into hydrocarbons. These hydrocarbons flowed into empty spaces in the surrounding rocks, called traps. Finally, an oil-soaked rock—much like a wet sponge—was formed. The traps were covered with a layer of solid rock, or a seal of salt or clay, that kept the oil and gas from escaping to the surface. Crude oil is held inside the rock formation, similar to how a sponge holds water.

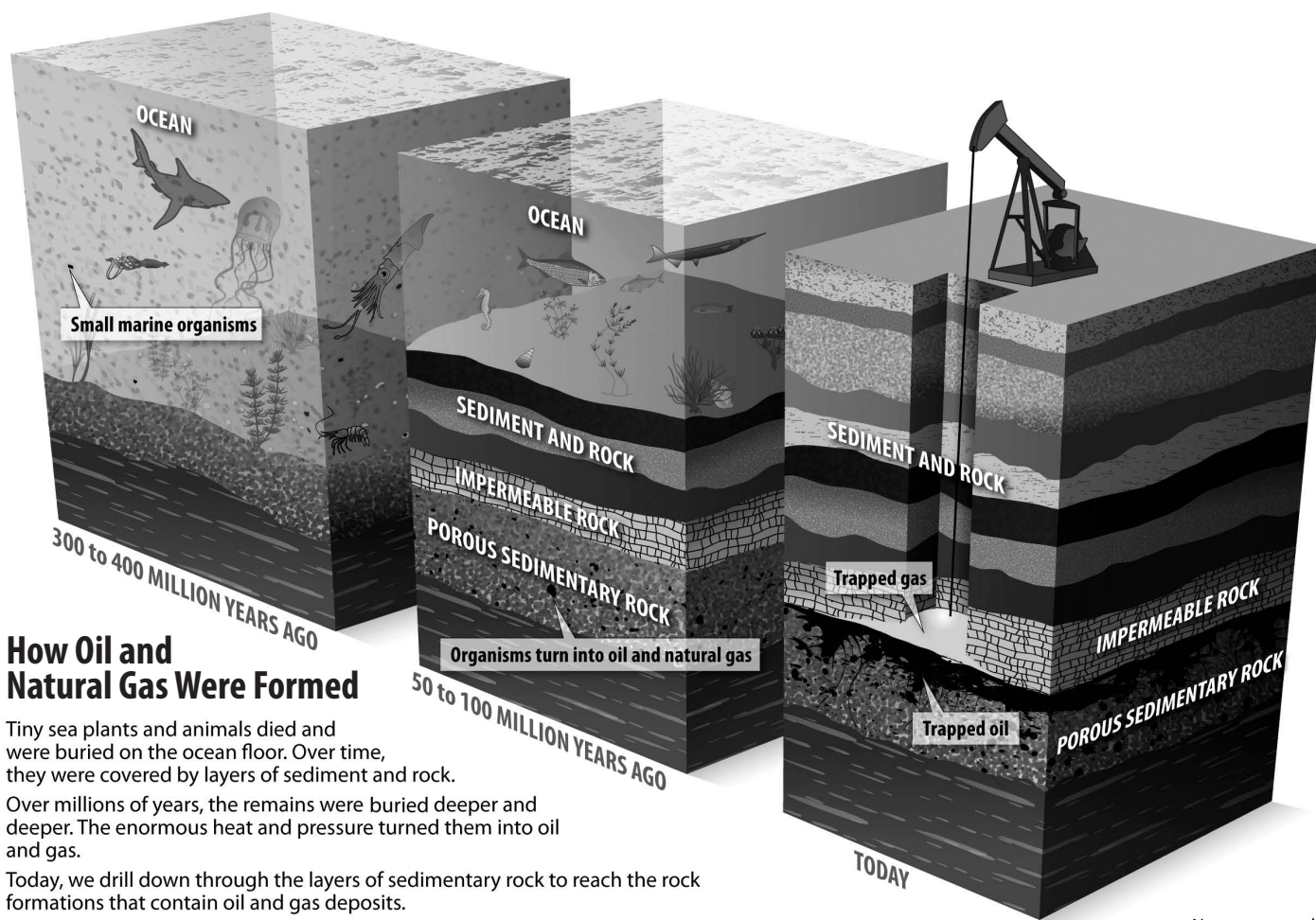

### How Oil and Natural Gas Were Formed

Tiny sea plants and animals died and were buried on the ocean floor. Over time, they were covered by layers of sediment and rock.

Over millions of years, the remains were buried deeper and deeper. The enormous heat and pressure turned them into oil and gas.

Today, we drill down through the layers of sedimentary rock to reach the rock formations that contain oil and gas deposits.

Note: not to scale

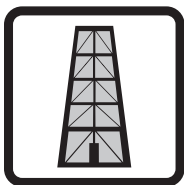

## EXPLORATION ACTIVITY

# Exploring Sound Waves

### Question

---

- How do sound waves travel?

### Materials

---

- 1 Metal slinky spring
- 1 Large foam cup
- 1 Small foam cup

### Procedure

---

#### Longitudinal Waves

1. Place the slinky on the floor so the coils are all together facing up. Place the large foam cup inside of the slinky coils and press in gently.
2. Lift the cup straight up. The end coils should come up around the center of the cup.
3. Place your hand around a few coils in the cup's middle to hold the slinky in place.
4. Bounce your hand up and down to create longitudinal waves and observe the sound vibrations echoing from the cup.
5. Repeat your hand motions at different heights—low and high—to hear the different sound vibrations and see the longitudinal waves produced.
6. Remove the large cup and repeat the investigation with the small cup.

#### Conclusions

---

- Was there a difference in longitudinal waves produced from the trials at different heights? Describe.
- What was the difference in the two sounds you heard from the two different cups?
- Explain how seismic technology uses sound to locate specific geologic formations underground.



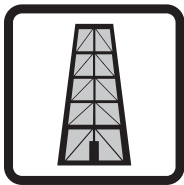

## EXPLORATION ACTIVITY

# Exploring Core Sampling

### Question

---

- Are all core samples the same?

### Materials

---

- 1 Bag of dark sand
- 1 Bag of light sand
- 1 Bag of soil
- 1 Bag of small gravel (aquarium size)
- 1 Clear plastic straw per student
- 1 Opaque plastic cup per student (8 ounce)
- Water in a spray bottle
- Plastic spoons
- Ruler

**NOTE:** When layering earth materials in cups, you can arrange the layers in any order.

### Procedure

---

1. Using the ruler to measure, place a 1 cm layer of one of the earth materials in the cup with a spoon. Mist with the spray bottle of water until damp, but not soaking.
2. Place another earth material 1 cm deep on top of the first layer. Moisten with water until damp.
3. Continue alternating layers of earth materials and water. The total height of the layers stacked in the cup will be 4 cm deep.
4. Trade cups with someone so you are not pulling a core sample from your own cup.
5. Use a straw to extract a core sample by pushing the straw straight down through the layers in the cup.
6. Place your finger tightly over the top end of the straw and withdraw it from the cup. Observe the layers in the straw core sample.
7. Lay several core samples from different cups side by side. Compare results.

### **\*\* Conclusions**

---

- What are core samples?
- Did you encounter any challenges when pulling up your core sample? If so, what was the challenge? How does this relate to real world drilling?
- What are petroleum geologists looking for when they examine core samples?

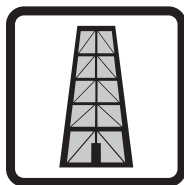

## PRODUCTION ACTIVITY

# Exploring Density

### Question

- Do all liquids have the same densities?

### Materials for each group

- 100 mL Graduated cylinder
- 600 mL Beaker
- Corn syrup
- Water, dyed with food coloring
- Vegetable oil
- Plastic button
- Grape
- Small cork
- Penny
- Glass marble
- Wooden bead
- Ice cube

### Procedure

- Pour 100 mL each of corn syrup, vegetable oil, and water into the beaker.
- Let the liquids settle for a few minutes. Observe what happens.
- One at a time, gently drop each object into the container.
- Observe where the objects settle.

### \*\* Conclusions

- What did you learn about the densities of liquids?
- What did you learn about the densities of objects?

### Extension

| ELEMENT  | DENSITY AT 20 °C          |
|----------|---------------------------|
| Hydrogen | 0.00008 g/cm <sup>3</sup> |
| Carbon   | 2.25 g/cm <sup>3</sup>    |
| Oxygen   | .00131 g/cm <sup>3</sup>  |
| Sodium   | 0.97 g/cm <sup>3</sup>    |
| Chlorine | .00295 g/cm <sup>3</sup>  |
| Calcium  | 1.54 g/cm <sup>3</sup>    |
| Zinc     | 7.14 g/cm <sup>3</sup>    |
| Bromine  | 3.12 g/cm <sup>3</sup>    |
| Gold     | 19.32 g/cm <sup>3</sup>   |

Density is defined as mass per unit volume ( $D = m/v$ ). The density of water is the standard at 1.00 g/cm<sup>3</sup>. Discuss the densities of the elements in the chart above. Use the formula for density to calculate the following densities:

- 1000 cm<sup>3</sup> of oil with a mass of 881 g: \_\_\_\_\_
- 100 cm<sup>3</sup> of aluminum with a mass of 270 g: \_\_\_\_\_
- 10 cm<sup>3</sup> of copper with a mass of 89.3 g: \_\_\_\_\_
- 200 cm<sup>3</sup> of nickel with a mass of 1780 g: \_\_\_\_\_

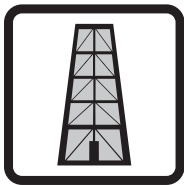

**PRODUCTION ACTIVITY**

# Exploring Porosity

**Question**

- Which size gravel will have the greatest porosity? Why is this?

**Materials** FOR EACH GROUP

- 350 cm<sup>3</sup> Large gravel (coarse gravel)
- 350 cm<sup>3</sup> Small gravel (aquarium type)
- 350 cm<sup>3</sup> Medium gravel (pea gravel)
- Water (can be dyed with food coloring)
- 3 600 mL Beakers or tall clear cups or jars
- 100 mL Graduated cylinder

**Procedure**

1. Fill one beaker to the 350 mL mark with the large coarse gravel. Fill the second beaker with 350 mL of medium pea gravel. Lastly, fill the third beaker with 350 mL of small aquarium gravel.
2. Fill the graduated cylinder with 100 mL of water.
3. Slowly pour water into the first beaker until the water reaches the top of the rocks. Record exactly how much water you poured into the beaker. If you need more than 100 mL of water, fill the graduated cylinder again.
4. Follow Step 3 again for the other two beakers filled with gravel.
5. Calculate the porosity of the three materials using this formula:

$$\text{Porosity} = \frac{\text{Volume of Water}}{\text{Volume of Material}} \times 100$$

| TYPE OF MATERIAL | VOLUME (mL) OF WATER Poured | VOLUME (cc) OF MATERIAL | PERCENTAGE OF PORE SPACE IN MATERIAL |
|------------------|-----------------------------|-------------------------|--------------------------------------|
| Large gravel     |                             |                         |                                      |
| Medium gravel    |                             |                         |                                      |
| Small gravel     |                             |                         |                                      |

**\*\* Conclusions**

- Which size of gravel has the greatest porosity? Explain why.
- Explain porosity's importance in the drilling process of an oil well.

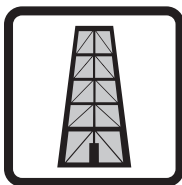

## PRODUCTION ACTIVITY

# Getting the Oil Out

Activity courtesy of SPE

Artificial lifting systems, or pumping units, are used to help pull the oil out of the reservoir rock and pump it up the well. A down hole pump in the well is connected to the pumping unit by steel rods, which are screwed together. The pump is activated from the up and down movement of the pumping unit on the surface. As the pump plunges down, fluid from the rock formation flows into the pump chamber. On the upstroke, the fluid in the chamber is forced up the tubing, to the surface.

### Question

- Will it be easier to bring up liquid with a long straw system, or a short straw system?

### Materials FOR EACH STUDENT OR PAIR

- 8-10 Drinking straws
- Masking tape
- Scissors
- Ruler
- Carton of chocolate milk or other beverage  
(Preferably a dark color so it can be seen through the straw)

### Procedure

1. Using the scissors, cut a 1 cm slit at one end of each straw.
2. Join the straws end to end to form one long tube. Place the slit end of the straw into the inside of the adjoining straw.
3. Place masking tape over each connected end to secure the joint and create an air tight seal.
4. Place the carton of chocolate milk (or other beverage) on the floor. One member of the group stands on a chair and inserts the extended straw "tubing" into the beverage trying to bring the liquid to the top of the "tubing" using his/her suction.
5. Now, decrease the number of straws used for the "tubing" by cutting off one straw. The same student tries to bring the liquid to the top.
6. Continue cutting off one straw at a time. After each cut try to bring the liquid to the top of the tubing.

### \*\* Conclusions

- Which length of straw required the most effort to bring the liquid to the top? Which length of straw required the least effort to bring the liquid to the top? Explain why.

### Extensions

- Try to pull up liquids of different viscosities and densities.
- Try using straws of different diameters to make your tubing.
- Study the diagram of the artificial lift system. Use the diagram to estimate how the system works to retrieve oil. Record your thinking in your science notebook. Using the *Oil and Natural Gas* book or internet sources, perform research to see how a horsehead pump actually works.

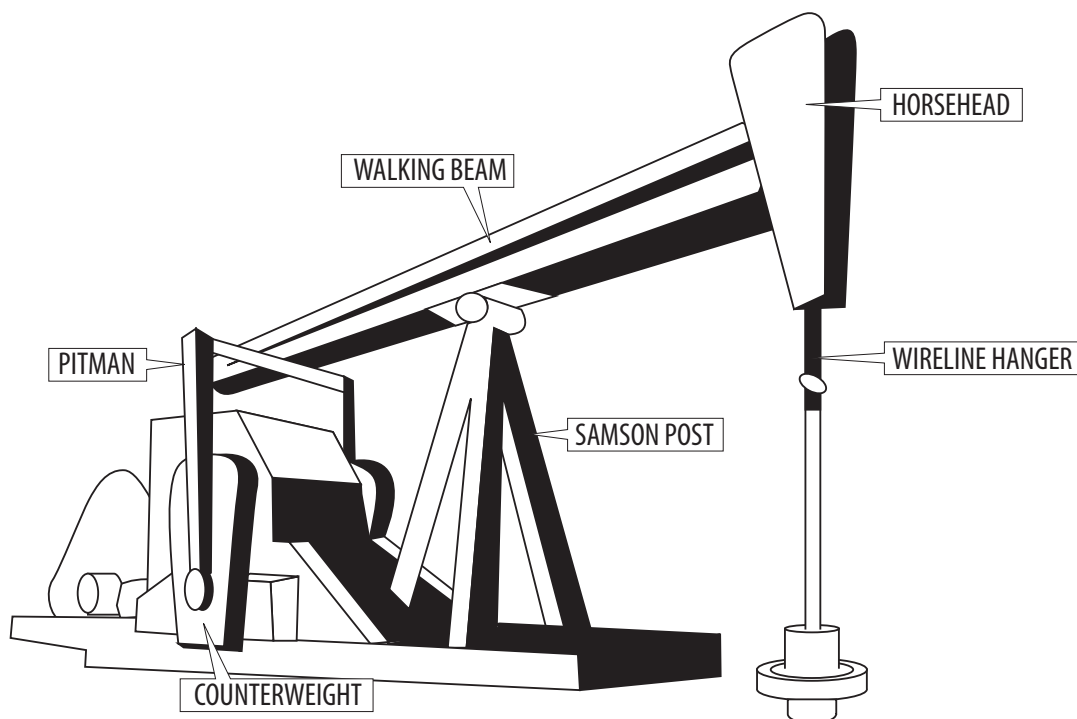



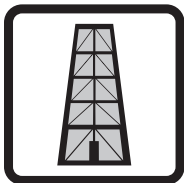

## REFINING ACTIVITY

# Distillation Products

### Question

---

- What products are made from crude oil?

### Materials

---

- Master of *Fractional Distillation* graphic, page 44
- Refinery Product Cards*, page 45
- Projector
- White board

### Preparation

---

- Make a master of the *Fractional Distillation* graphic that you can share with your class using an LCD or overhead projector.
- Copy the *Refinery Product Cards* on card stock and cut out each product.
- Draw a thermometer on the board with a range of 0 to 700°C.

### Procedure

---

1. Distribute one *Refinery Product Card* to each student. Instruct each student to write the uses and importance of his/her product on the back of the card. Give the students ten minutes to research information about their products.
2. Display the *Fractional Distillation* master and instruct each student to find his/her product on the graph and note the boiling point.
3. Point out that the density of the products increases as the number of carbon atoms in the products increases.
4. Explain that the activity involves heating crude oil as shown on the thermometer on the board. Explain that you will decrease the temperature of the crude oil by 10°C at a time. Ask the students to hold up their hands as their products are being separated out from the crude oil.
5. When the students raise their hands, ask each in turn to stand up and tell the class the uses and important facts about his/her product.



# Fractional Distillation

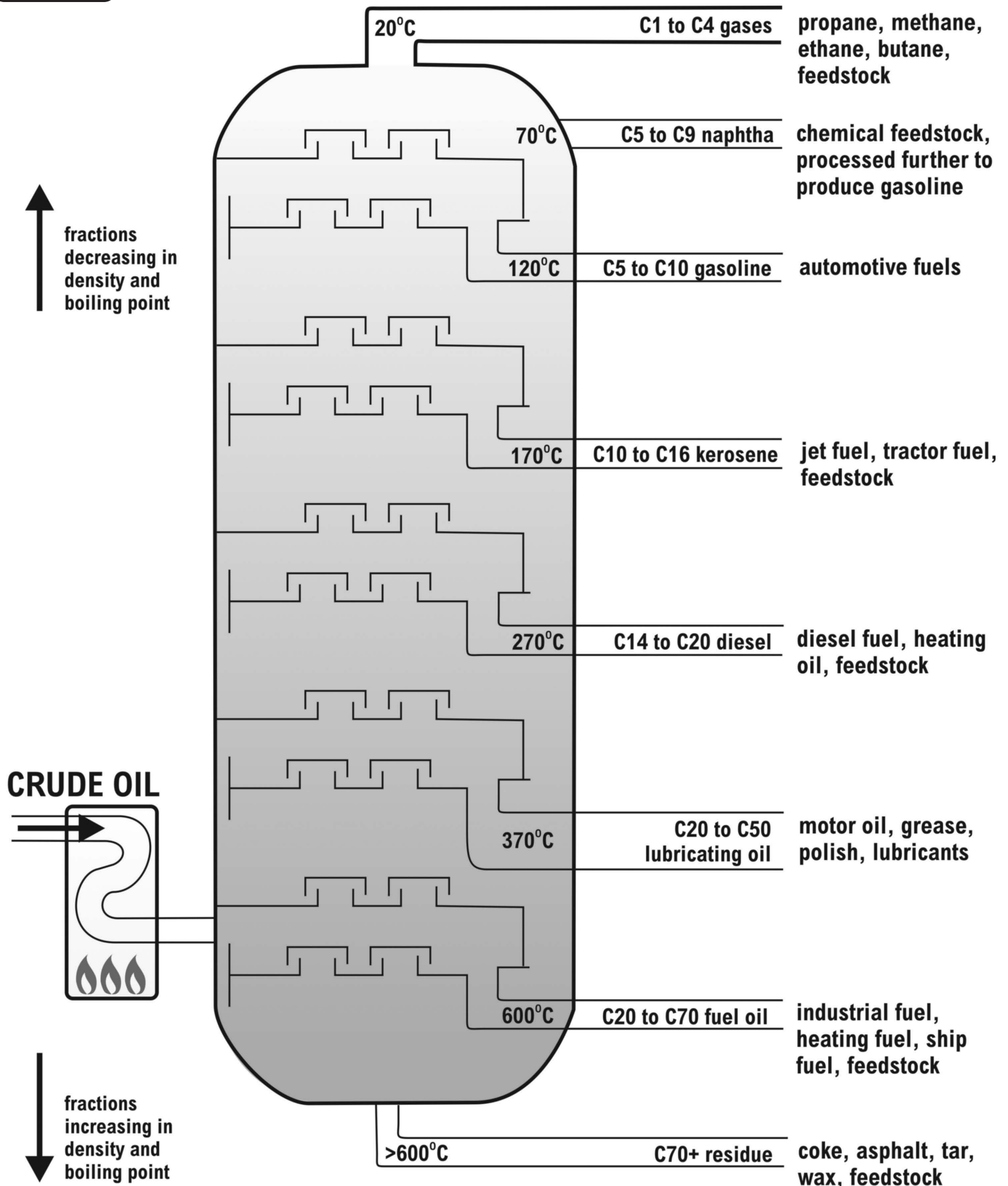

# Refinery Product Cards

|                                    |                            |                            |
|------------------------------------|----------------------------|----------------------------|
| propane                            | jet fuel                   | industrial fuel oil        |
| methane                            | tractor fuel               | heating fuel oil           |
| ethane                             | kerosene                   | feedstock<br>from fuel oil |
| butane                             | feedstock<br>from kerosene | coke                       |
| petroleum gas<br>feedstock         | diesel fuel                | asphalt                    |
| chemical<br>feedstock              | heating oil                | tar                        |
| gasoline<br>from processed naphtha | feedstock<br>from diesel   | wax                        |
| high octane<br>gasoline            | motor oil                  | feedstock<br>from residue  |
| mid octane<br>gasoline             | grease                     | fuel for ships             |
| regular octane<br>gasoline         | lubricants                 | shoe polish                |



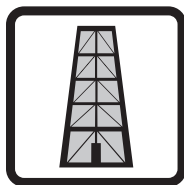

## REFINING ACTIVITY - TEACHER DEMONSTRATION

# The Refining Process

### Question

- How can different products be separated out of one solution?

### Materials

- 400 mL 2% Milk
- 100 mL Vinegar
- Saucepan
- Wooden spoon
- Hot plate
- Pot holder
- Safety glasses

### Safety

This demonstration uses a hot plate and liquid that will become hot. Review safety guidelines with students about not touching the hot plate, even after it is turned off. Everyone should wear safety glasses to protect themselves against potential spatter.

### Procedure

1. Explain to students that this activity uses a solution of milk and vinegar as a model for crude oil.
2. Have the class brainstorm products that are made from milk. Do students know how those products get made? Explain that milk is boiled to produce many of the products.
3. In a place where all students can see, turn on the hot plate. Pour in the milk and vinegar into the saucepan. Stir until the substances have separated into curds and whey. (Approximately 1-3 minutes.)
4. Ask the students, "What caused the milk and vinegar mixture to separate?"
5. Explain to students how this experiment is similar to the separation of crude oil into usable parts. Crude oil is refined through a heating process to separate it into different substances before it can be made into usable products.

### Conclusions

- What caused the milk solution to change forms?
- Explain how the milk solution is like crude oil during the refining process.
- How does the oil and gas industry use this science in the refining process?

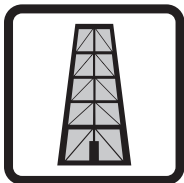

## CHEMICAL MANUFACTURING ACTIVITY

# Polymers

During fractional distillation crude oil is separated into useful parts. A petrochemical is a product of the fractional distillation process. Usually consisting of long chains, a monomer is a link in the chain. All of the monomer links connected together make a polymer chain.

Chemically bonded monomers form polymers in a process called polymerization. Polymers created from petrochemicals are synthetic or man-made polymers. We use many of these polymers, such as plastics, everyday.

## Polymer One

---

### Materials

---

- Cornstarch
- Water
- Sealable plastic sandwich bags
- Measuring spoons
- Food coloring
- Paper plates

### Procedure

---

1. Put 6 tablespoons of cornstarch in a plastic bag.
2. Add 5 drops of food coloring.
3. Add 4 tablespoons of water.
4. Close the bag and mix together by kneading.
5. If the polymer seems too runny (you cannot pick it up), add a spoonful of cornstarch to thicken. If the polymer seems too thick or crumbly (dry), add a spoonful of water to make it thinner.
6. Open the bag and pour the polymer onto the plate.
7. Use your finger to gently poke the polymer. What happens?
8. Now quickly poke the polymer. What happens?
9. Pick the polymer up. What happens?
10. Roll the polymer in a ball. What happens?

### Conclusion

---

- Is this polymer a liquid or a solid? Explain.

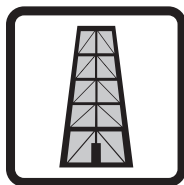

# Polymers

## Polymer Two

---

### Materials

---

- White glue
- Borax
- Water
- Spoon or popsicle stick to stir
- Small plastic cups
- Food coloring
- Graduated cylinder
- Ruler
- Sealable plastic sandwich bags

### Preparation

---

- Make a borax solution: about 6 mL of borax to 235 mL of water.

### Procedure

---

1. Use the ruler to measure and mark 1 cm from the bottom of the small plastic cup.
2. Add white glue to the 1 cm mark.
3. Add a few drops of food coloring and mix.
4. Measure 7 mL of water in the graduated cylinder and add to the glue. Mix well and pour into a plastic bag.
5. Measure 8 mL of the borax solution using the graduated cylinder and add to the glue solution in the plastic bag. Mix well by kneading.
6. If it is too sticky, add borax solution one drop at a time. If it is too stringy, add glue one drop at a time.
7. Once the polymer is formed, you may remove it from the cup and knead it.
8. Pull your polymer apart, string it out, twist it, and roll it into a ball.
9. Write your observations about your polymer.

### Conclusions

---

- What happened when you combined the glue solution and the borax solution?
- Explain how this is a polymer.

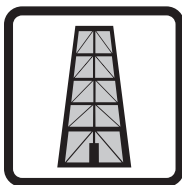

## CHEMICAL MANUFACTURING ACTIVITY

# Slush Powder

### Vocabulary

**Polymer:** a large organic molecule formed by combining many smaller molecules (monomers) in a regular pattern.

**Monomer:** a molecule that can combine with other molecules to form a polymer.

**Dissociate:** to split into simpler groups of atoms, single atoms, or ions.

### Background

The chemical name for slush powder is sodium polyacrylate. It is a polymer containing many repeating molecules called acrylate monomers connected end-to-end in a large chain. Sodium acrylate is a chain made of carbon, oxygen, hydrogen, and sodium. Cross-links between the sodium acrylate chains (-----) tether the chains together into sodium polyacrylate. These repeating molecules can be thousands to millions of units long.

Sodium polyacrylate, nicknamed the “super slurper,” is called a superabsorber because it has the ability to absorb large quantities of water. It can absorb 400-800 times its mass in water, but does not dissolve into a solution because of its three-dimensional network structure. Its liquid-like properties result from the fact that the polymer is composed almost entirely of water. Its solid-like properties are due to the network formed by the cross-links.

Sodium polyacrylate is called a hydrophilic or “water-loving” polymer because of its great affinity for water. So how does this polymer work? In its dry powdered state, the chains of the polymer are coiled and lined with carboxyl groups (–COOH). When water is added, the carboxyl groups dissociate into negatively charged carboxylate ions (COO<sup>-1</sup>). These ions repel one another along the polymer chain, widening the polymer coils and allowing water to move into contact with more carboxyl groups. As the polymer continues to uncoil, it becomes a gel.

Sodium polyacrylate is used as an absorbent material in disposable diapers and to retain water around plants. It is considered non-toxic, but inhalation of airborne particles of the powder or contact with the eye can cause serious adverse reactions. It is for this reason that using a disposable diaper to obtain the powder is discouraged.

To dispose of the gel, add salt. The presence of salt in the solution greatly decreases the ability of the polyacrylate to absorb and retain water. Once the gel has liquefied, it can be safely poured down a drain.

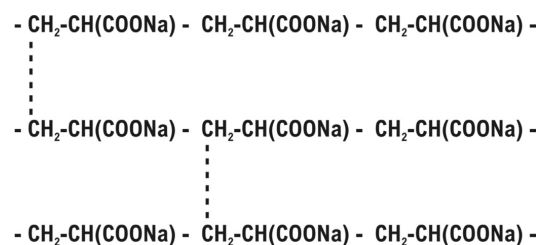

### Materials

- Sodium polyacrylate
- 400 mL Beaker
- 100 mL Beaker
- Water
- Salt (optional)

### Procedure

1. Place 1 cc (mL) of sodium polyacrylate in the 400 mL beaker.
2. Add 10 mL of water to the beaker. Observe.
3. Continue adding water 10 mL of water at a time until the sodium polyacrylate absorbs no more water.

### Extension

- Experiment with varying strengths of saltwater solution to determine how much a given amount of sodium polyacrylate can absorb. Use a one percent saltwater solution for this experiment, since urine is approximately one percent saline (4.5 mL of salt to 1 liter of water).

### \*\* Conclusions

- Describe what happened to the polymer as you added water.
- Why does the polymer stop absorbing water?
- Explain how polymers like this one fit into the refining process.



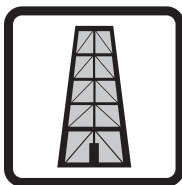

## CHEMICAL MANUFACTURING ACTIVITY

# Chemical Hazard Placards

Chemical hazard placards are placed on laboratories and rooms in which specific chemicals are used and stored to let safety personnel know of the dangers. They are also used on vehicles that transport chemicals. The placards have four squares—three colored squares and one open square that represent different types of hazards. The levels of the hazards are written in the squares, as defined in the placard below.

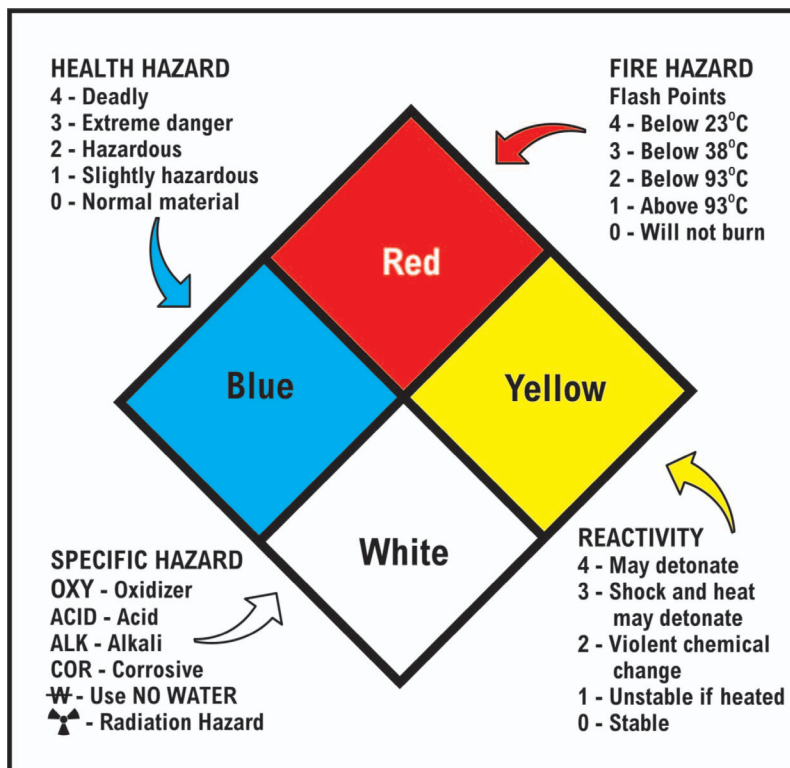

## Defining Terms

Define the following words using the *Fossil Fuels to Products Glossary* or a dictionary:

**Acid:**

**Alkali:**

**Corrosive:**

**Detonate:**

**Oxidizer:**

**Unstable:**

## Temperature Conversions

Convert the flash points on the Fire Hazards from Celsius to Fahrenheit using the formula:  $F = \frac{9}{5} C + 32$

23°C =

38°C =

93°C =

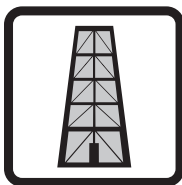

## CHEMICAL MANUFACTURING ACTIVITY

# Identifying Chemical Hazard Placards

Below are six chemical hazard placards and six descriptions of different chemicals. Read the chemical descriptions and match each chemical to its chemical hazard placard.

\_\_\_\_\_ **CALCIUM** is a silvery, moderately hard, metallic element that constitutes about three percent of the Earth's crust and is a basic component of most animals and plants. It occurs naturally in limestone, gypsum, and fluorite, and its compounds are used to make plaster, quicklime, Portland cement, and metallurgic and electronic materials. It can be slightly hazardous to human health, and is slightly flammable. It can produce a violent reaction when it comes into contact with water.

**Physical State:** solid    **Boiling Point:** 1,487°C    **Appearance:** silver-white    **Odor:** odorless

\_\_\_\_\_ **METHANE**, CH<sub>4</sub>, is an odorless, colorless, flammable gas that is the major constituent of natural gas. It is used as a fuel and is an important source of hydrogen and a wide variety of organic compounds. It is hazardous to human health and is an extreme fire hazard. It is a stable gas.

**Physical State:** gas    **Flash Point:** -188°C    **Appearance:** colorless    **Odor:** odorless

\_\_\_\_\_ **BENZENE** is a colorless, very flammable, toxic, liquid, aromatic hydrocarbon, C<sub>6</sub>H<sub>6</sub>, derived from petroleum and used in or to manufacture a wide variety of chemical products, including solvents, detergents, insecticides, and motor fuels. It can be hazardous to human health. It is a stable compound.

**Physical State:** liquid    **Boiling Point:** 80°C    **Appearance:** colorless    **Odor:** gasoline-like

\_\_\_\_\_ **BUTANE** is either of two isomers of a gaseous hydrocarbon, C<sub>4</sub>H<sub>10</sub>, produced from petroleum and used as a household fuel, refrigerant, aerosol propellant, and in the manufacture of synthetic rubber. It can be slightly hazardous to human health and is an extreme fire hazard. It is a stable compound.

**Physical State:** gas    **Flash Point:** -76°C    **Appearance:** colorless    **Odor:** faint, disagreeable

\_\_\_\_\_ **SULFURIC ACID** is a highly corrosive, dense, colorless, oily liquid, H<sub>2</sub>SO<sub>4</sub>, used to manufacture a wide variety of chemicals and materials including fertilizers, paints, detergents, and explosives. It can pose an extreme danger to human health and is unstable, capable of causing violent chemical change. Reacts violently with water.

**Physical State:** liquid    **Boiling Point:** 290°C    **Appearance:** colorless    **Odor:** sulfurous

\_\_\_\_\_ **PHOSPHORUS** is a highly reactive, deadly poisonous, nonmetallic element occurring naturally in phosphates. It is used in safety matches, pyrotechnics, fertilizers, and to protect metal surfaces from corrosion. It is extremely flammable and is unstable, capable of violent chemical change.

**Physical State:** solid    **Boiling Point:** 280°C    **Appearance:** white-to-yellow    **Odor:** odorless

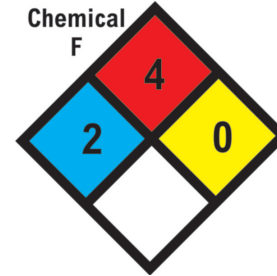
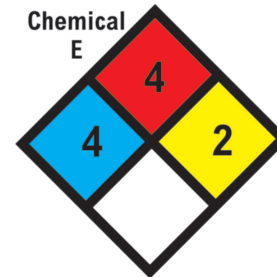
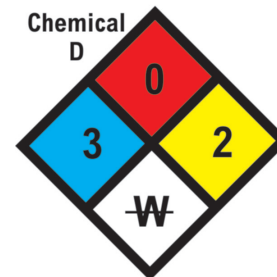
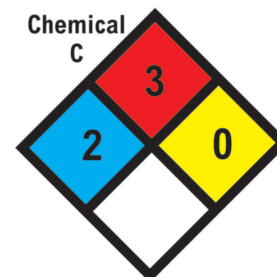
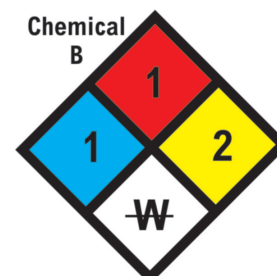
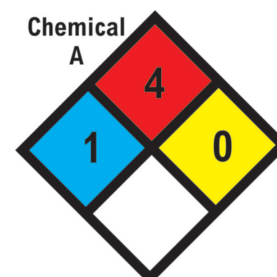

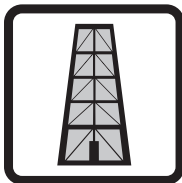

## CHEMICAL MANUFACTURING ACTIVITY

# Make a Chemical Hazard Placard

Make your own chemical hazard placard. Choose a chemical you've heard about and research its characteristics and uses, then draw a placard for the chemical using the blank placard below. Display your placard and tell your classmates about the characteristics and uses of your chemical.

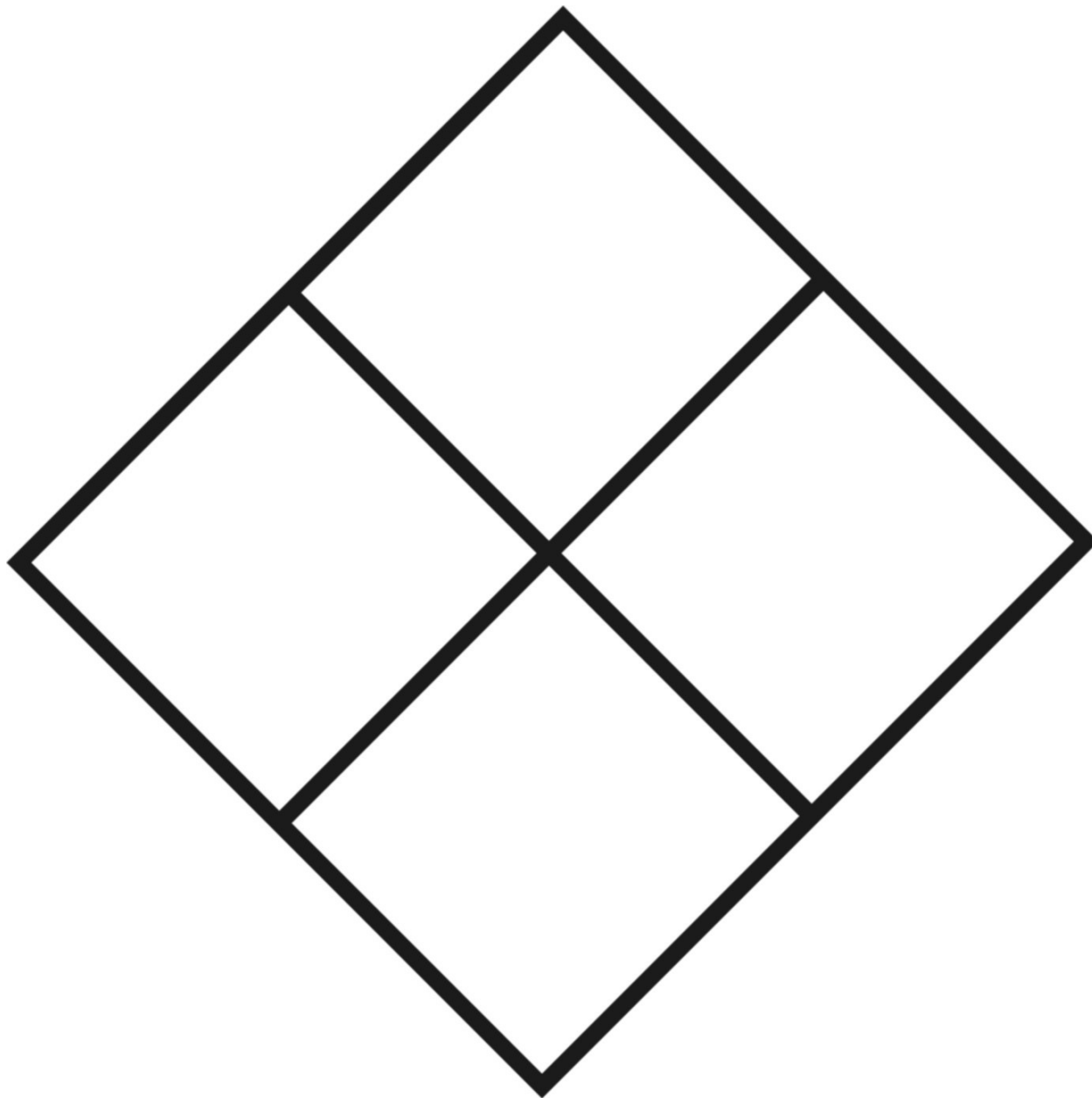

**Chemical:**

**Chemical Formula:**

**Characteristics:**

**Uses:**



# Pretzel Power

## 🎯 Objective

The students will recognize the energy efficiency of different kinds of transportation and the benefits of carpooling.

## 📄 Materials

- 3" x 5" Cards
- Internet access for students (see note below)
- Bag of pretzels
- Plastic sandwich bags
- Three signs (Home, Near Town, Far Town)

## 🛠️ Preparation

1. Prepare a plastic bag with ten pretzels for each student.
2. Make three signs, one labeled "Home" one labeled "Near Town" and one labeled "Far Town." The signs should be large enough to see from across the room.
3. Select a large area and place the Home, Near Town, and Far Town signs on poles or walls. The distance to Near Town should be 50 steps. The distance to Far Town should be 100 steps. (Do not give these distances to students.)

## ✅ Procedure

1. Have students look up a car they would like to drive on [www.fueleconomy.gov](http://www.fueleconomy.gov). On 3" x 5" cards, students should record the car's name, model year, miles per gallon, and the number of passengers the car holds.  
**NOTE:** If you would prefer, you can download pre-made automobile cards from [www.NEED.org](http://www.NEED.org). If you would like to print the cards on labels use Avery 5392.
2. Distribute a bag of pretzels to each student. Tell students not to eat the pretzels until they are told to.
3. Explain to the students that each pretzel represents one gallon of gasoline, and each step (heel-to-toe) the student takes represents one mile traveled.
4. Students eat a pretzel and take the appropriate number of steps before eating the next pretzel. All steps are heel-to-toe.

## ① Round One

- Use only 5 pretzels for this round. Each person will drive his/her car. Work in "Near Town" and return "Home." If anyone runs out of fuel (pretzels), he/she must stay at that point until round one is over. Line up at "Home" and start stepping!  
**DISCUSS:** Which cars got you to work and home? Which didn't?
- Did anyone have extra fuel remaining?
- What alternatives to driving your own car are there?

## ② Round Two

- Use the remaining five pretzels, try some of the suggestions discussed above. Expect "negotiations." Suggest students carpool to work. Drivers may eat each passenger's pretzels as fuel. Everyone will travel to "Far Town" and return "Home." Line up at "Home" and start stepping!  
**DISCUSS:** Who made it to "Far Town" and back? How did you do this?
- Who did not make it to "Far Town" and back? Why not?



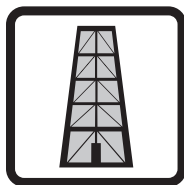

# Oil Industry in the Round

|   |  |   |
|---|--|---|
| <p><b>I have Alteration. THE END</b><br/> <b>START:</b> Who has a name for fuels formed from the remains of ancient sea plants and animals?</p> | <p><b>I have Metamorphic.</b><br/>           Who has the study of rock layers to determine the origin and composition of rocks?</p>                | <p><b>I have Drilling Mud.</b><br/>           Who has the term used to describe the gaps or pores where oil is stored?</p>                    |
| <p><b>I have Fossil Fuel.</b><br/>           Who has the term for energy sources that take millions of years to form?</p>                       | <p><b>I have Stratigraphy.</b><br/>           Who has the measure of a rock's ability to hold and move fluids?</p>                                 | <p><b>I have Porosity.</b><br/>           Who has the process used to turn an exploratory well into a production well?</p>                    |
| <p><b>I have Nonrenewable.</b><br/>           Who has the name of the main component of natural gas?</p>  | <p><b>I have Permeability.</b><br/>           Who has the technology that uses sound waves to explore underground rock formations?</p>             | <p><b>I have Completion.</b><br/>           Who has the term used to indicate the amount of water in an oil deposit?</p>                      |
| <p><b>I have Methane.</b><br/>           Who has the type of rock made from layers of sand and sediment?</p>                                    | <p><b>I have Seismic.</b><br/>           Who has a device used to create underground shock waves?</p>  | <p><b>I have Saturation.</b><br/>           Who has the term that describes nearby oil reserves that are not connected to each other?</p>     |
| <p><b>I have Sedimentary.</b><br/>           Who has the energy source consumed the most in the U.S.?</p>                                       | <p><b>I have Thumper.</b><br/>           Who has an advanced visualization technology used to understand seismic data?</p>                         | <p><b>I have Compartmentalization.</b><br/>           Who has the device used to regulate high pressure in a production well?</p>             |
| <p><b>I have Petroleum.</b><br/>           Who has the area that produces a third of all crude oil in the U.S.?</p>                             | <p><b>I have CAVE.</b><br/>           Who has a new type of seismic technology that measures changes over time?</p>                                | <p><b>I have Blow Out Preventor (BOP).</b><br/>           Who has the term used when a well has enough pressure to lift the oil?</p>          |
| <p><b>I have Offshore.</b><br/>           Who has the sector of the economy that uses 71 percent of U.S. oil?</p>                               | <p><b>I have 4D Seismic.</b><br/>           Who has the structure used to test for underground oil with an exploratory well?</p>                   | <p><b>I have Natural Drive.</b><br/>           Who has the process of separating crude oil into its major components using boiling range?</p> |
| <p><b>I have Transportation.</b><br/>           Who has the type of rock that is formed from magma?</p>   | <p><b>I have Drilling Rig.</b><br/>           Who has the term for petroleum products that are used to make other products in chemical plants?</p> | <p><b>I have Distillation.</b><br/>           Who has the process of using heat to break long hydrocarbon chains into smaller chains?</p>     |
| <p><b>I have Igneous.</b><br/>           Who has the type of gases that keep the Earth warm enough for human life?</p>                          | <p><b>I have Feedstocks.</b><br/>           Who has the term for the rock that is disturbed by the drilling process?</p>                           | <p><b>I have Thermal Cracking.</b><br/>           Who has the process of combining short hydrocarbon chains into longer chains?</p>           |
| <p><b>I have Greenhouse.</b><br/>           Who has the type of rock made from extensive heat and pressure on other rocks?</p>                  | <p><b>I have Debris.</b><br/>           Who has the term for the material used to lift debris from a well?</p>                                     | <p><b>I have Unification.</b><br/>           Who has the process of rearranging the molecules in hydrocarbon chains?</p>                      |

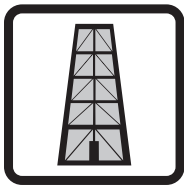

# Synthesis Activity

## 🎯 Objective

Students will create a flow chart mural of petroleum from formation to disposal, with each student representing a different product.

## 📄 Materials

- Large piece of mural paper
- Colored markers

## ☑ Procedure

1. Assign a product role to each student, using the list below and/or any others you wish:  
asphalt, aspirin, butane, carpeting, CD, coke, naphtha, contact lenses, cosmetics, crayon, credit card, diaper, diesel fuel, electricity, fertilizer, glue, grease, hand lotion, heating oil, industrial fuel, jet fuel, laundry detergent, ethane, lubricants, methane, milk jug, gasoline, motor oil, paint, pen ink, trash bag, plastic container, propane, prosthetic heart valve, soda bottle, tar, tire, toothbrush, toothpaste, tractor fuel, wax, shoe polish
2. Have each student prepare a flow chart of his/her product's lineage from formation to final product to use or disposal.
3. Explain to the students that after they create their personal flow charts, they will create a classroom flow chart that includes the lineage of every product in the class. Have the students brainstorm ideas for creating a combined flow chart. They will need to find out what the products have in common within each lineage and may find it helpful to group themselves by boiling point or some other characteristic. Once students have discovered and agreed upon patterns in their flow charts, sketch out a master flow chart on large chart paper at the front of the room.
4. All products started out as ancient sea plants and animals, so formation can go at the beginning of the flow chart. Offshore and onshore exploration and production can divide into two areas, and then the flow chart can come back together after transportation to the refining phase. After refining, have the students begin to add their individual products to the flow chart. Some products will move straight to transportation and market, others to chemical processing, then to market. Have students add product uses to the flow chart.
5. Have the students add colored lines to the flow chart detailing the way their products are transported from origin to market; pipeline = red, truck = blue, ship = green, for example.
6. Brainstorm disposal methods for some products that are not consumed, such as plastic objects. See NEED's *Museum of Solid Waste and Energy* for information on preferred disposal methods for plastics and other waste products.
7. Have students answer the following discussion questions in their science journals.

## 🗨 Discussion Questions

1. What do CDs and diesel fuel have in common?
2. What do you think is the most important product created from crude oil? Why do you think so?

## 📖 Extension

Discuss question two as a group. List each student's opinion of the most important product derived from crude oil. Debate the choices. For example, which is more important, diesel fuel to ship goods, gasoline for personal transportation, medicines, or plastics for heart valves?

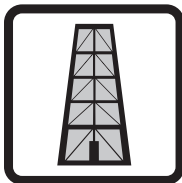

# Fossil Fuels to Products Pre/Post Survey

- Petroleum and natural gas are:**
  - fossil fuels
  - nonrenewables
  - hydrocarbons
  - all three
- Which energy source meets more energy demand than any other in the United States?**
  - natural gas
  - petroleum
  - solar
  - coal
- Petroleum and natural gas are usually found in which type(s) of rock formations?**
  - sedimentary
  - metamorphic
  - igneous
  - all three
- Which sector of the economy uses the highest percentage of petroleum products?**
  - industrial
  - residential
  - commercial
  - transportation
- Geologists using advanced technologies to explore for oil are successful what percentage of the time?**
  - 20 percent
  - 60 percent
  - 80 percent
  - 100 percent
- What percentage of oil does the U.S. import from other countries?**
  - 20-30 percent
  - 40-50 percent
  - 60-70 percent
  - 80-90 percent
- What percentage of oil does the industrial sector in the U.S. use for energy and to manufacture products?**
  - 2 percent
  - 12 percent
  - 22 percent
  - 32 percent
- How much U.S. oil production comes from offshore wells?**
  - 10 percent
  - 33 percent
  - 50 percent
  - 75 percent
- Crude oil must be processed before it can be used.**
  - true
  - false
- Most crude oil is processed into diesel fuel for trucks, boats, trains, and other heavy vehicles.**
  - true
  - false
- Crude oil must be processed at a refinery before it is usable by consumers.**
  - true
  - false
- Refineries separate petroleum products according to their boiling point by distillation.**
  - true
  - false
- Crude oil contains only liquid products.**
  - true
  - false
- Most petroleum products are transported by large oil tankers.**
  - true
  - false
- Chemical plants make thousands of different chemicals, plastics, medicines, cosmetics, clothing, tires, and other products we use every day from petroleum products.**
  - true
  - false
- The price of oil affects all sectors of the U.S. economy.**
  - true
  - false

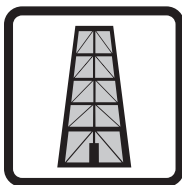

# Glossary

|                                 |   |
|---------------------------------|---|
| <b>acid</b>                     | any of various water-soluble compounds having a sour taste and capable of turning litmus red and reacting with a base to form a salt            |
| <b>alkali</b>                   | any substance having basic (as opposed to acidic) properties  |
| <b>alkylation</b>               | mixing a hydrocarbon with a catalyst and an acid to create different hydrocarbons   |
| <b>alteration</b>               | a process that rearranges pieces of hydrocarbon chains into different hydrocarbons  |
| <b>aromatic</b>                 | cyclic hydrocarbon in the shape of a ring rather than a chain   |
| <b>blow out preventor (BOP)</b> | a device that controls the pressure of a well   |
| <b>boiler</b>                   | equipment used to process petroleum products with heat  |
| <b>casing</b>                   | process of lining a production well with pipe before production can begin   |
| <b>catalytic cracking</b>       | using a catalyst to break long hydrocarbon chains   |
| <b>catalytic reformatting</b>   | using a catalyst to rearrange hydrocarbon chains  |
| <b>CAVE</b>                     | Cave Automatic Virtual Environment; sophisticated technology for visualizing data from seismic systems  |
| <b>cementing</b>                | stabilizing a casing pipe in a production well with cement  |
| <b>christmas tree</b>           | a series of valves and gauges that control the flow of a well with natural drive  |
| <b>coke</b>                     | a carbon-rich substance used by heavy industry  |
| <b>coking</b>                   | heating the residue from the distillation process to produce useful products such as coke   |
| <b>compartmentalization</b>     | a situation in which oil from one part of a reserve cannot flow to another part of the reserve because of characteristics of the rock formation |
| <b>completion</b>               | preparing an exploratory well for production  |
| <b>condense</b>                 | to change state from gas to liquid  |
| <b>cooling tower</b>            | equipment used to cool water that has been heated during chemical processing  |
| <b>corrosive</b>                | having the capability or tendency to cause corrosion or gradual destruction   |
| <b>cracking</b>                 | a process that breaks long hydrocarbon chains into shorter chains   |
| <b>data log</b>                 | comprehensive information about a well's production data over time  |
| <b>debris</b>                   | the rock that is torn up by a drill bit and must be removed from a well   |
| <b>density</b>                  | a measure of the amount of mass contained in a given volume   |
| <b>detonate</b>                 | to set off an explosion   |
| <b>distillation</b>             | separation of substances based on their boiling range   |
| <b>drilling rig</b>             | the equipment used to drill a well  |
| <b>drilling mud</b>             | the substance used to lift debris from a well during drilling   |
| <b>exploratory well</b>         | a well dug to find out if oil or natural gas is present in a location   |
| <b>field processing</b>         | processing of crude oil at an offshore production site to separate the crude oil, natural gas, and saltwater                                    |
| <b>fossil fuel</b>              | energy-rich hydrocarbon made from the ancient remains of organic matter   |
| <b>fractioning tower</b>        | equipment in which distillation takes place   |
| <b>greenhouse gas</b>           | any gas in the atmosphere that contributes to the greenhouse effect   |
| <b>heat exchanger</b>           | a device that uses waste heat from one chemical process in another process  |
| <b>heat-treater</b>             | a device used to remove water from crude oil  |
| <b>horse head pump</b>          | a pump with a crank arm that lifts oil to the surface of a production well  |
| <b>hydrocarbon</b>              | a chemical compound containing only hydrogen and carbon   |
| <b>igneous rock</b>             | rock formed from magma or liquid rock that exists inside the Earth  |



|                                   |  |
|-----------------------------------|--|
| <b>loading station</b>            | an area where products are stored until shipped to market  |
| <b>mercaptan</b>                  | an odorant added to natural gas as a safety feature  |
| <b>metamorphic rock</b>           | rock with few pores made from sedimentary or igneous rock under intense pressure   |
| <b>methane</b>                    | the main ingredient in natural gas   |
| <b>monomer</b>                    | a molecule that can combine with other molecules to form a polymer   |
| <b>mud</b>                        | the substance used to lift debris from a well during drilling  |
| <b>natural drive</b>              | pressure in a production well with enough force to lift the crude oil to the surface   |
| <b>nonrenewable energy source</b> | an energy source that takes millions of years to form  |
| <b>olefin</b>                     | a hydrocarbon that contains one or more pairs of carbon atoms linked by a double bond  |
| <b>organic compound</b>           | a compound containing hydrogen and carbon made of once living material   |
| <b>oxidizer</b>                   | a substance that gives up oxygen easily to stimulate combustion of organic material  |
| <b>perforating</b>                | making holes in the bottom portion of a casing pipe so that oil can flow into it   |
| <b>permeability</b>               | a measure of the ability of a rock to hold and move fluids   |
| <b>pig</b>                        | a device used to clean a pipeline  |
| <b>polymer</b>                    | a large organic molecule formed by combining many smaller molecules (monomers) in a regular pattern                                  |
| <b>porosity</b>                   | relating to the pores or gaps between the grains of rock in which oil is stored  |
| <b>pressurized separator</b>      | a device that uses pressure to quickly separate crude oil, natural gas, and saltwater during field processing                        |
| <b>processing platform</b>        | an offshore platform where oil is cleaned and combined with oil from other wells before it is sent to a refinery                     |
| <b>pumping station</b>            | a device along a pipeline with pumping equipment to keep the product flowing through the pipeline                                    |
| <b>renewable energy source</b>    | an energy source that can be replenished in a short period of time   |
| <b>roustabout</b>                 | a worker on a drilling rig   |
| <b>ROVER</b>                      | a Remote Operating Vehicle used to maintain and repair undersea drilling equipment   |
| <b>saturation</b>                 | the amount of water contained in crude oil   |
| <b>sedimentary rock</b>           | rock formed from layers of sand and sediment under pressure  |
| <b>seismic technology</b>         | equipment that bounces sound waves off of underground rock to determine the characteristics of rock formations                       |
| <b>settling tank</b>              | a tank used to separate crude oil, natural gas, and saltwater on a processing platform   |
| <b>smart pig</b>                  | a device that uses a camera to monitor a pipeline for flaws  |
| <b>stratigraphy</b>               | the study of rock layers to determine data about the rock formation, the age of the layers, the radioactivity, and other information |
| <b>sucker-rod pump</b>            | a pump that draws crude oil to the surface of a production well  |
| <b>tank farm</b>                  | a group of oil storage tanks   |
| <b>thermal cracking</b>           | a process that uses very high temperatures to break apart long hydrocarbon chains  |
| <b>thumper</b>                    | a device that produces sound waves in seismic technology   |
| <b>treatment</b>                  | process of removing impurities from petroleum products before they are shipped to market   |
| <b>unification</b>                | a process that combines smaller hydrocarbon chains into longer chains  |
| <b>unstable</b>                   | having a tendency to react easily with other substances  |
| <b>wastewater treatment</b>       | processes that ensure that the water leaving a chemical plant is as clean as when it entered the plant                               |

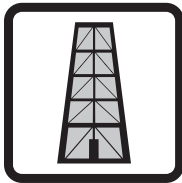

# Fossil Fuels to Products Evaluation Form

State: \_\_\_\_\_ Grade Level: \_\_\_\_\_ Number of Students: \_\_\_\_\_

- 1. Did you conduct the entire unit?  Yes  No
- 2. Were the instructions clear and easy to follow?  Yes  No
- 3. Did the activities meet your academic objectives?  Yes  No
- 4. Were the activities age appropriate?  Yes  No
- 5. Were the allotted times sufficient to conduct the activities?  Yes  No
- 6. Were the activities easy to use?  Yes  No
- 7. Was the preparation required acceptable for the activities?  Yes  No
- 8. Were the students interested and motivated?  Yes  No
- 9. Was the energy knowledge content age appropriate?  Yes  No
- 10. Would you teach this unit again?  Yes  No

*Please explain any 'no' statement below.*

How would you rate the unit overall?  excellent  good  fair  poor

How would your students rate the unit overall?  excellent  good  fair  poor

What would make the unit more useful to you?

---

---

---

---

Other Comments:

---

---

---

---

Please fax or mail to: **The NEED Project**  
P.O. Box 10101  
Manassas, VA 20108  
FAX: 1-800-847-1820

# NEED National Sponsors and Partners

American Association of Blacks in Energy  
American Chemistry Council  
American Electric Power  
American Electric Power Foundation  
American Solar Energy Society  
American Wind Energy Association  
Appalachian Regional Commission  
Aveva  
Arkansas Energy Office  
Armstrong Energy Corporation  
Association of Desk & Derrick Clubs  
Robert L. Bayless, Producer, LLC  
BP  
BP Alaska  
C&E Operators  
Cape and Islands Self Reliance  
Cape Cod Cooperative Extension  
Cape Light Compact–Massachusetts  
L.J. and Wilma Carr  
Central Virginia Community College  
Chevron  
Chevron Energy Solutions  
ComEd  
ConEdison Solutions  
ConocoPhillips  
Council on Foreign Relations  
CPS Energy  
Dart Foundation  
David Petroleum Corporation  
Desk and Derrick of Roswell, NM  
Dominion  
Dominion Foundation  
DTE Energy Foundation  
Duke Energy  
East Kentucky Power  
El Paso Foundation  
E.M.G. Oil Properties  
Encana  
Encana Cares Foundation  
Energy Education for Michigan  
Energy Training Solutions  
Energy Solutions Foundation  
Entergy  
Equitable Resources  
First Roswell Company  
Foundation for Environmental Education  
FPL  
The Franklin Institute  
GenOn Energy–California  
Georgia Environmental Facilities Authority  
Government of Thailand–Energy Ministry  
Guam Energy Office  
Gulf Power  
Halliburton Foundation  
Hawaii Energy  
Gerald Harrington, Geologist  
Houston Museum of Natural Science  
Hydro Research Foundation  
Idaho Department of Education  
Idaho National Laboratory  
Illinois Clean Energy Community Foundation  
Independent Petroleum Association of America  
Independent Petroleum Association of New Mexico  
Indiana Michigan Power  
Interstate Renewable Energy Council  
iStem–Idaho STEM Education  
Kansas City Power and Light  
KBR  
Kentucky Clean Fuels Coalition  
Kentucky Department of Education  
Kentucky Department of Energy Development and Independence  
Kentucky Oil and Gas Association  
Kentucky Propane Education and Research Council  
Kentucky River Properties LLC  
Kentucky Utilities Company  
Lenfest Foundation  
Littler Mendelson  
Llano Land and Exploration  
Los Alamos National Laboratory  
Louisville Gas and Electric Company  
Maine Energy Education Project  
Maine Public Service Company  
Marianas Islands Energy Office  
Massachusetts Division of Energy Resources  
Lee Matherne Family Foundation  
Michigan Oil and Gas Producers Education Foundation  
Midwest Energy Cooperative  
Mississippi Development Authority–Energy Division  
Montana Energy Education Council  
The Mosaic Company  
NADA Scientific  
NASA  
National Association of State Energy Officials  
National Fuel  
National Grid  
National Hydropower Association  
National Ocean Industries Association  
National Renewable Energy Laboratory  
Nebraska Public Power District  
New Mexico Oil Corporation  
New Mexico Landman’s Association  
New Orleans Solar Schools Initiative  
New York Power Authority  
NSTAR  
OCI Enterprises  
Offshore Energy Center  
Offshore Technology Conference  
Ohio Energy Project  
Pacific Gas and Electric Company  
PECO  
Petroleum Equipment Suppliers Association  
Phillips 66  
PNM  
Puerto Rico Energy Affairs Administration  
Puget Sound Energy  
Rhode Island Office of Energy Resources  
RiverWorks Discovery  
Roswell Climate Change Committee  
Roswell Geological Society  
Sacramento Municipal Utility District  
Saudi Aramco  
Schneider Electric  
Science Museum of Virginia  
C.T. Seaver Trust  
Shell  
Snohomish County Public Utility District–WA  
Society of Petroleum Engineers  
SolarWorld USA  
David Sorenson  
Southern Company  
Southern LNG  
Southwest Gas  
Space Sciences Laboratory–University of California Berkeley  
Tennessee Department of Economic and Community Development–Energy Division  
Tennessee Valley Authority  
Toyota  
TXU Energy  
United States Energy Association  
University of Nevada–Las Vegas, NV  
U.S. Department of Energy  
U.S. Department of Energy–Hydrogen Program  
U.S. Department of Energy–Office of Energy Efficiency and Renewable Energy  
U.S. Department of Energy–Office of Fossil Energy  
U.S. Department of Energy–Wind for Schools  
U.S. Department of Energy–Wind Powering America  
U.S. Department of the Interior–Bureau of Land Management  
U.S. Department of the Interior–Bureau of Ocean Energy Management, Regulation and Enforcement  
U.S. Energy Information Administration  
U.S. Environmental Protection Agency  
Van Ness Feldman  
Virgin Islands Energy Office  
Virginia Department of Education  
Virginia Department of Mines, Minerals and Energy  
Walmart Foundation  
Washington and Lee University  
Western Kentucky Science Alliance  
W. Plack Carr Company  
Yates Petroleum Corporation